

Digital AlphaServer™ 400 Series

User Information

Order Number: EK-PCSVU-UI. A01

Digital Equipment Corporation
Maynard, Massachusetts

January 1995

The information in this document is subject to change without notice and should not be construed as a commitment by Digital Equipment Corporation.

Digital Equipment Corporation assumes no responsibility for any errors that might appear in this document.

The software, if any, described in this document is furnished under a license and may be used or copied only in accordance with the terms of such license. No responsibility is assumed for the use or reliability of software or equipment that is not supplied by Digital Equipment Corporation or its affiliated companies.

Restricted Rights: Use, duplication, or disclosure by the U.S. Government is subject to restrictions as set forth in subparagraph (c) (1) (ii) of the Rights in Technical Data and Computer Software clause at DFARS 252.227-7013.

Copyright © 1995 Digital Equipment Corporation.
All Rights Reserved.

The following are trademarks of Digital Equipment Corporation:

AlphaGeneration, AlphaServer, AlphaStation, DEC, Digital, OpenVMS, and the DIGITAL logo.

The following are third-party trademarks:

Microsoft and Windows NT are registered trademarks of Microsoft Corporation.

SIMM is a trademark of Molex Corporation.

OSF/1 is a trademark of the Open Software Foundation, Inc.

All other trademarks and registered trademarks are the property of their respective holders.

This document was produced with Microsoft Word for Windows, V2.0c.

FCC Information - Class B

FCC ID: AO9-PB50

This device complies with Part 15 of the FCC rules. Operation is subject to the following conditions:

- (1) this device may not cause harmful interference, and
- (2) this device must accept any interference received, including interference that may cause undesired operation.

This equipment has been tested and found to comply with the limits for a Class B digital device, pursuant to Part 15 of the FCC rules. These limits are designed to provide reasonable protection against harmful interference in a residential installation. Any changes or modifications to this equipment may void the user's authority to operate this equipment.

This equipment generates, uses, and can radiate radio frequency energy and, if not installed and used in accordance with the instructions, may cause harmful interference to radio communications. However, there is no guarantee that interference will not occur in a particular installation. If this equipment does cause harmful interference to radio or television reception, which can be determined by turning the equipment off and on, the user is encouraged to try to correct the interference by one or more of the following measures:

- Re-orient or relocate the receiving antenna
- Increase the separation between the equipment and the receiver
- Connect the equipment into an outlet on a circuit different from that to which the receiver is connected
- Consult the dealer or an experienced radio/TV technician for help

The keyboard and video ports should be connected only with shielded datacables with an external ferrite bead over the cable. When either of these ports is connected with cables without such a ferrite bead, the additional ferrite beads shall be clamped over these cables next to the cable connector.

Contents

Preface

Welcome to the Digital AlphaServer 400 Series System	xiii
Audience	xiii
Organization of the Information.....	xiv
Conventions.....	xiv
Abbreviations	xv
Special Notices.....	xvii
Additional Information Resources	xviii

1 Getting Started

Introduction.....	1-1
Before Starting Your System	1-2
Posture and Work Habits	1-2
Identifying the Correct AC Power Cord	1-4
System Features.....	1-6
Installing Your System	1-8
Connecting System Parts.....	1-9
Network Connection.....	1-11
Starting Your System.....	1-11
Preloaded Operating System Software	1-12
Microsoft Windows NT Server.....	1-12
DEC OSF/1.....	1-12
OpenVMS.....	1-13
Switching Console Firmware	1-13
If No Operating System Is Installed	1-13
Turning Off Your System	1-14
Computer Security.....	1-15
Chassis Lock.....	1-15

Contents

Security Loop	1-15
Passwords	1-15

2 System Overview

Introduction	2-1
Motherboard	2-1
PCI Architecture	2-1
SCSI Controller	2-2
Keyboard	2-2
System Front View	2-4
System Rear View	2-6

3 Installing System Options

Introduction	3-1
Removing the Side Panels	3-1
System Unit Components	3-3
Motherboard	3-4
Installing Additional System Memory	3-6
Memory Configurations	3-6
Adding Memory Modules	3-7
Installing Expansion Boards	3-8
Adding Mass Storage Devices	3-10
Expansion Brackets	3-10
SCSI Bus Length	3-10
SCSI Addresses	3-10
SCSI Termination	3-11
Internal Termination	3-11
External Termination	3-11
Installing Devices in the Upper Drive Bay Area	3-12
Installing Devices in the Lower Drive Bay Area	3-17

4 Troubleshooting

Introduction	4-1
Initial Troubleshooting	4-1
Equipment Log	4-2
General Troubleshooting	4-2
Error Beep Codes	4-7
Diagnostic LEDs	4-7
Interpreting the LED Indicator Values	4-8

A Console Commands

Introduction.....	A-1
ARC Console.....	A-1
Commands You Need to Know	A-2
Display Hardware Configuration.....	A-2
Set Default Environment Variables	A-2
Set Default Configuration	A-2
Manage Boot Selection Menu	A-2
Machine Specific Setup.....	A-3
Boot "boot selection identifier".....	A-3
Boot an Alternate Operating System	A-3
Other Commands of Interest	A-3
Setup Autoboot	A-3
Install New Firmware.....	A-3
Install Windows NT from CD-ROM	A-4
Switch to OpenVMS or OSF Console.....	A-4
SRM Console	A-5
SRM Console Conventions	A-5
SRM Console Special Characters.....	A-6
Boot Command.....	A-7
Boot Command Examples.....	A-8
Set Command	A-9
Set Command Examples	A-9
Show Command.....	A-10
Show Command Examples.....	A-11
Examine Command	A-12
Examine Command Examples	A-13
Deposit Command	A-14
Deposit Command Examples	A-15
Environment Variables	A-16
ISA Configuration Utility	A-17
Command Format	A-17
Adding ISA Options to OpenVMS and DEC OSF/1 Systems	A-19
ISACFG Command Examples.....	A-20

B System Care

Introduction.....	B-1
Cleaning Your System Unit	B-1
Cleaning Your Monitor.....	B-1
Cleaning Your Mouse.....	B-2
Cleaning Your Keyboard	B-2

Contents

Moving Your System.....	B-3
Packing Your System.....	B-3
Installing Your System at a New Location.....	B-3

C Technical Specifications

Introduction.....	C-1
System Specifications.....	C-1
External System Connectors.....	C-3
Bidirectional Parallel Port Connector.....	C-3
Serial Port Connectors.....	C-4
Keyboard and Mouse Connectors.....	C-4
SCSI Port Connector.....	C-5
Expansion Slots.....	C-6
Power Supply and Input Power Requirements.....	C-6
Jumpers.....	C-6
Motherboard Jumpers.....	C-6
CPU Module Jumpers.....	C-8

D Device Mapping

Introduction.....	D-1
I/O Address Map.....	D-1
Interrupt Map.....	D-2
DMA Channel Assignments.....	D-3

E Updating System Firmware

Introduction.....	E-1
System Firmware.....	E-1
Update Utility.....	E-1
Flash Enable Jumper.....	E-1
Using the Flash Update Utility From the SRM Console.....	E-2
Using the Flash Update Utility From the ARC Console.....	E-4

F Starting an Operating System Installation

Introduction.....	F-1
Starting a Windows NT Server Installation.....	F-2
Starting a DEC OSF/1 Installation.....	F-5
Starting an OpenVMS Installation.....	F-6

G Equipment Log

Introduction.....G-1
 Equipment Log.....G-1

Index

Figures

1-1 Digital AlphaServer 400 Series System 1-1
 1-2 Recommendations for Posture and Work Habits..... 1-3
 1-3 System Airflow 1-8
 1-4 Voltage Selector Switch 1-9
 1-5 Connecting Cables and Power Cords 1-10
 1-6 Starting Your System 1-11
 2-1 Keyboard Layout..... 2-3
 2-2 Front Controls and Indicators 2-4
 2-3 Rear Connectors..... 2-6
 3-1 Unlocking and Removing Left Side Panel 3-2
 3-2 System Unit Components 3-3
 3-3 Motherboard Components 3-4
 3-4 Memory Banks 3-6
 3-5 Installing a SIMM 3-7
 3-6 Installing an Expansion Board..... 3-9
 3-7 Removing Plastic Filler Panel from the Upper Drive Bay..... 3-12
 3-8 Removing the Metal Plate 3-13
 3-9 Exchange Bracket Mounting 3-13
 3-10 Inserting a Device into the Upper Drive Bay 3-14
 3-11 SCSI and FDC Cable Configuration 3-15
 3-12 Power Cable Configuration 3-16
 3-13 Removing the Lower Drive Bay Assembly..... 3-18
 3-14 Removing the Lower Drive Bay Devices..... 3-19
 B-1 Cleaning the Mouse..... B-2
 C-1 Motherboard Jumper Locations C-7
 C-2 CPU Module Jumper Locations..... C-8

Tables

1-1 Recommendations for Posture and Work Habits..... 1-3
 2-1 Key Groups and Functions 2-3
 2-2 Front Controls and Indicators 2-5
 2-3 Rear Connectors..... 2-7

Contents

3-1	System Unit Components.....	3-3
3-2	Motherboard Components.....	3-5
3-3	SCSI Address Recommendations.....	3-11
4-1	System Troubleshooting.....	4-2
4-2	Disk Drive Troubleshooting.....	4-6
4-3	Monitor Troubleshooting.....	4-6
4-4	Error Beep Codes.....	4-7
4-5	LED Codes.....	4-8
A-1	SRM Console Conventions.....	A-5
A-2	SRM Console Special Characters.....	A-6
A-3	SRM Boot Command Options.....	A-7
A-4	SRM Boot Command Examples.....	A-8
A-5	SRM Set Command Options.....	A-9
A-6	SRM Set Command Examples.....	A-9
A-7	SRM Show Command Options.....	A-10
A-8	SRM Show Command Examples.....	A-11
A-9	SRM Examine Command Options.....	A-12
A-10	SRM Examine Command Examples.....	A-13
A-11	SRM Deposit Command Options.....	A-14
A-12	SRM Deposit Command Examples.....	A-15
A-13	SRM Environment Variables.....	A-16
A-14	SRM ISACFG Command Options.....	A-17
A-15	Adding Options to OpenVMS or DEC OSF/1 Systems.....	A-19
C-1	Computer Performance Specifications.....	C-1
C-2	Computer Dimensions.....	C-2
C-3	Computer Environmental Specifications.....	C-2
C-4	Acoustics-Declared Values per ISO 9296 and ISO 7779.....	C-2
C-5	Bidirectional Parallel Port Pinouts.....	C-3
C-6	E-Pin Serial Port Pinouts.....	C-4
C-7	Keyboard and Mouse Connector Pinouts.....	C-4
C-8	SCSI Port Pinouts.....	C-5
C-9	Computer Input Power Requirements.....	C-6
C-10	Motherboard Jumper Settings.....	C-8
C-11	CPU Module Jumper Settings.....	C-9
D-1	I/O Address Map.....	D-1
D-2	System Interrupt Assignments.....	D-2
D-3	DMA Channel Assignments.....	D-3
F-1	Starting a Windows NT Server Installation.....	F-2
F-2	Setting Up Partitions for a Windows NT Server Installation.....	F-3
F-3	Starting a DEC OSF/1 Installation.....	F-5
F-4	Starting an OpenVMS Installation.....	F-6
G-1	Hardware Components.....	G-2
G-2	ISA Equipment Configuration Chart.....	G-3

Contents

G-3	SCSI Addresses.....	G-3
G-4	System Hardware Configuration.....	G-4
G-5	Installed Software.....	G-4
G-6	Additional Component Information.....	G-4

Preface

Welcome to the Digital AlphaServer 400 Series System

This guide introduces the Digital AlphaServer 400 Series system.

Use the information here to start, use, update, troubleshoot, and configure your Digital AlphaServer 400 Series system. You also can find general system information such as console commands and system care here.

Audience

If you are operating, configuring, or adding options to the Digital AlphaServer 400 Series system, the information included here is helpful to you.

Organization of the Information

This information for users covers the following topics (see the Table of Contents for a detailed listing):

- Chapter 1, *Getting Started*. Installing, starting, restarting, and turning off the system
- Chapter 2, *System Overview*. Motherboard, keyboard, system controls, indicators, ports, and connections
- Chapter 3, *Installing System Options*. Installing hard disk, compact disc, and tape drives, memory, option cards, printer cable, and external SCSI cable
- Chapter 4, *Troubleshooting*. Possible causes and actions to solve problems
- Appendix A, *Console Commands*
- Appendix B, *System Care*. Cleaning your system, monitor, and mouse
- Appendix C, *Technical Specifications*
- Appendix D, *Device Mapping*. I/O addresses and interrupts
- Appendix E, *Updating System Firmware*
- Appendix F, *Starting an Operating System Installation*
- Appendix G, *Equipment Log*

Conventions

This guide uses the following conventions:

Convention Example	Description
c:\windows	Monospaced text indicates file names, path names, directories, or screen text. Each operating system has its own specific syntax.
[Enter]	Square brackets surrounding text represent a key on the keyboard.
[Ctrl]+[R]	A plus sign indicates that you press the keys shown at the same time.
<i>auto_action</i>	Italic text indicates environment variables. Italic is occasionally used for emphasis in the text. Also, titles of information sources are shown in italic type.
	A pointing hand indicates a reference to additional information.

Abbreviations

This guide uses the following abbreviations:

Abbreviation	Meaning
ARC	Advanced RISC Computing (the Windows NT Console).
CD	Compact disc.
CD-ROM	Compact disc read only memory.
CPU	Central processing unit.
DMA	Direct memory access.
DRAM	Dynamic random access memory.
DROM	Diagnostic read only memory.
FAT	File allocation table.
FDC	Floppy disk controller.
flashROM	Electrically erasable, rewriteable, nonvolatile memory.
GB	A GB suffix to a numerical value indicates size in <i>gigabytes</i> (for example, 1 GB). A gigabyte equals 1,073,741,824 bytes.
IRQ	Interrupt request.
ISA	Industry-standard architecture.
Kb	A Kb suffix to a numerical value indicates size in <i>kilobits</i> (for example, 512 Kb). A kilobit equals 1024 bits.
KB	A KB suffix to a numerical value indicates size in <i>kilobytes</i> (for example, 640 KB). A kilobyte equals 1024 bytes.

(continued)

LED	Light-emitting diode.
MAU	Media Adapter Unit.
Mb	An Mb suffix to a numerical value indicates size in <i>megabits</i> (for example, 10 Mb). A megabit equals 1,048,576 bits.
MB	A MB suffix to a numerical value indicates size in <i>megabytes</i> (for example, 550 MB). A megabyte equals 1,048,576 bytes.
MHz	Megahertz.
ns	Nanoseconds.
NVRAM	Nonvolatile random access memory.
OSF	DEC OSF/1 operating system.
PCI	Peripheral component interconnect.
RAID	Redundant array of inexpensive disks.
RISC	Reduced instruction set computing.
ROM	Read only memory.
SCSI	Small computer system interface.
SIMM	Single in-line memory modules.
SRM	System reference manual, the OSF/1 and OpenVMS console.
SRAM	Serial read only memory.

Special Notices

This guide uses four kinds of notices to emphasize specific information.

WARNING

A **WARNING** indicates the presence of a hazard that can cause personal injury.

CAUTION

A **CAUTION** indicates the presence of a hazard that can cause damage to hardware or that might corrupt software.

NOTE

A **NOTE** gives general information, such as compatibility with other products or pointers to other information.

HINT

A **HINT** includes suggestions to make your computing tasks easier.

Additional Information Resources

You may wish to consult the following information resources on your Digital AlphaServer 400 Series system:

- *Digital AlphaServer™ 400 Series Installation Information* (order number EK-PCDSA-II) presents a graphical overview of the Digital AlphaServer 400 Series installation.
- *Digital AlphaStation™ 200/400 Series Technical Information* (order number EK-PCDSA-TI). This optional manual contains detailed technical information for value-added resellers (VARs) and independent software vendors.

Contact your distributor or Digital representative for other available product-related information.

Getting Started

Introduction

Your Digital AlphaServer 400 Series system is a high-performance computer that uses the latest microprocessor technology. The system can stand alone or function as a server in an office network environment.

This chapter describes how to start, install, restart, and turn off your Digital AlphaServer 400 Series system. You can also find information here about preloaded software as well as guidelines for system security. Figure 1-1 shows a typical Digital AlphaServer 400 Series system.

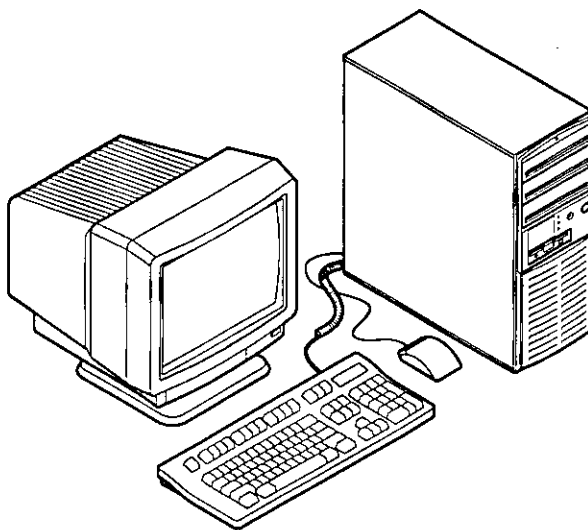

Figure 1-1. Digital AlphaServer 400 Series System

Getting Started

Before Starting Your System

Before you start your system, perform the following steps:

1. Read and understand the information supplied with your system.
2. Select a well-ventilated site near a grounded power outlet and away from sources of excessive heat. The site also should be isolated from electric noise (for example, spikes, sags, and surges) produced by devices such as air conditioners, large fans, radios, and televisions.
3. Save all shipping containers and packing material for repackaging or moving the system later.

NOTES

- a. Do not install optional hardware or application software until you have started your system and verified that the base system is working correctly.
 - b. On systems that have preloaded software, a label attached to the system unit informs you that licensed software has been installed. Carefully review the software license agreement shipped with your system.
-

WARNING

When unpacking and moving system components, be aware that some components (such as the system unit or monitor) may be too heavy for you to safely lift alone. If you are doubtful about whether you can lift these items alone, please get assistance.

Posture and Work Habits

If you exercise poor posture while you work or if your equipment is poorly set up, certain recent scientific articles suggest that personal injury may result. Other articles suggest that there is no cause and effect. Because the safety of our users is a great concern to Digital Equipment Corporation, we strongly urge that you read and follow the precautions outlined in Figure 1-2 and Table 1-1. In addition, be sure to adjust your work space so that you are comfortable, and change your position frequently.

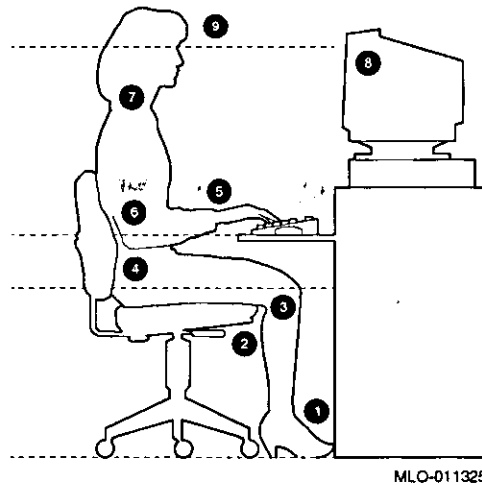

MLO-011325

Figure 1-2. Recommendations for Posture and Work Habits

Table 1-1. Recommendations for Posture and Work Habits

Adjust	To allow the following conditions
Chair	<ol style="list-style-type: none"> 1. Feet are flat on the floor. 2. Legs are vertical and form a right angle to the floor. 3. Your thighs are horizontal, and they are not bearing weight. Keep the backs of your knees away from the seat so you do not compress the area behind them, which could restrict the blood flow. 4. Your upper body is erect and your lower back is supported with a backrest.
Keyboard and Mouse	<ol style="list-style-type: none"> 5. Your wrists are straight and do not flex more than 15 degrees. They are supported and do not rest on sharp edges. If you use a mouse, rest your hand on the mouse so your wrist is not on the work surface. Operate the mouse close to your body's centerline. 6. Upper arms are straight down at your sides, and elbows are close to your sides and support your arm weight. Forearms are at a 70- to 90-degree angle.

Table 1-1. Recommendations for Posture and Work Habits (continued)

Adjust	To allow the following conditions
Head	7. Avoid neck strain. Your head should incline downward, but no more than 15 to 20 degrees.
Monitor	8. No higher than the level of your eyes and at the correct distance for your vision. 9. Avoid eye fatigue, which can be caused by glare, image quality, uncomfortable furniture, eye height, and uncorrected vision. If you cannot focus to read at different distances, you may need special glasses. Relax your eyes periodically by focusing on distant objects.
Lighting	Avoid direct lighting or sunlight on the screen, which causes glare and reflections. Place lighting behind or to the side of your work area, and distribute the lighting evenly on your work area.
Noise	Keep background noise at a minimum. Background noise above 65 dBA is tiring. Sound-absorbing materials (for example, curtains, carpeting, and acoustic tile) can help reduce background noise.
Temperature	20 –23 degrees C (68 - 74 degrees F)
Humidity	30% – 70%
Ventilation	Provide adequate air ventilation to operate the equipment and avoid fatigue.
Work Space	> 70 cm (28 inches) center to center, preferably between > 152 cm (60 inches).

WARNING

If you experience pain or discomfort while using your system, rest and review the instructions for posture and work habits. If the pain or discomfort continues after resuming work, discontinue use and report the condition to your job supervisor or physician.

Identifying the Correct AC Power Cord

Your Digital AlphaServer 400 Series system came with the proper AC power cord. Because there are variations from one country to another, and systems may be relocated, please inspect your power cord to ensure it is the correct one for your country or region. If you are not sure that the supplied AC power cord is correct, contact your authorized Digital service representative before you use it.

WARNING

Do not attempt to modify or use an external 115 Volts AC power cord for 230 Volts AC input power. Modifying the power cord can cause personal injury and severe equipment damage.

Power cords supplied with the Digital AlphaServer 400 Series system meet the following criteria:

- UL and CSA Certified cord rated for use at 250 Volts AC with a current rating that is at least 125% of the current rating of the Digital AlphaServer 400 Series system. In Europe, the cordage carries the <HAR> mark.
- The AC plug is terminated in a grounding-type male plug designed for use in the region. It must also have marks showing certification by an agency acceptable in the region.
- The connector at the computer end must be an IEC-type CEE-22 female connector.
- The cord length must not exceed 4.5 meters (14.5 feet).

System Features

Your Digital AlphaServer 400 Series system includes several features that enhance system reliability, ensure its availability, improve its expansion capabilities, and facilitate hardware management as well as improve system security.

Reliability/Availability	
64-bit Alpha RISC architecture	Provides significantly better performance than 32-bit architecture does.
Variable fan speed	Adjusts fan speed according to system temperature.
Longword parity	Provides easy detection of corrupted memory data.
System Expansion	
Flexible memory architecture	Provides a 64-bit data path. System memory can be upgraded from 16 MB to 192 MB using memory options.
Three ISA expansion slots, two PCI expansion slots, and one PCI/ISA combination expansion slot.	Accommodate industry-standard option cards such as Ethernet, FDDI, SCSI, and modems.
Integrated Fast SCSI-2 controller with external SCSI connector	Supports tape, CD-ROM, and hard disk drives without use of an expansion slot.
Capacity for five internal storage devices	Accommodates three 5.25-inch half-height drives, one 3.5-inch half-height drive, and one 3.5-inch diskette drive.
External ports	Two serial ports and one parallel port support external options such as a printer, modem, or local terminal.

(continued)

Server Management	
System diagnostics	Allows local and remote diagnosis of system problems.
Hardware configuration	Allows local and remote system configuration.
Unique asset management	Unique system identifier in nonvolatile memory provides easy asset management.
RAM-based error log	Records startup error messages.
Firmware upgrade utility	Provides verification of firmware versions.
System Security	
Key lock	Limits access to system components.
Security loop (on rear of system unit)	Allows system to be secured in place.

Getting Started

Installing Your System

The Digital AlphaServer 400 Series system *Installation Information* you received with your system graphically outlines the steps to follow in installing your system.

CAUTIONS

1. To ensure that your system is properly cooled, make sure that air can freely flow into the front and out of the rear of the system unit.
 2. The system is designed to be installed vertically. Do not use a stand or rack that would hold the system on its side.
-

Check to make sure that you received all your system components. (See Appendix G, Equipment Log, to list your equipment.) If something is missing, please contact your distributor or Digital representative.

Position your system so that air can flow freely to and from the vents, as shown in Figure 1-3.

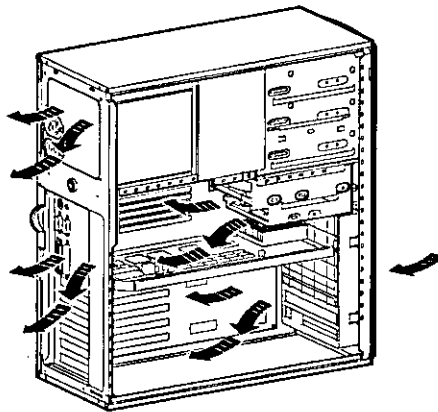

Figure 1-3. System Airflow

Connecting System Parts

To connect the components of your Digital AlphaServer 400 Series system, perform the following steps:

1. Confirm that the voltage selector switch matches your local voltage (either 115 Volts or 230 Volts), as Figure 1-4 shows.

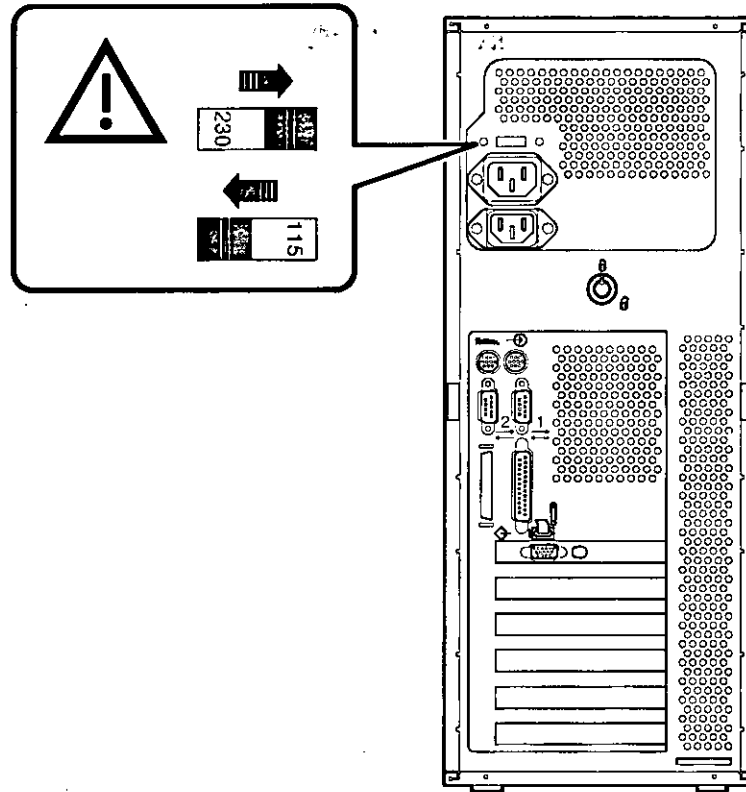

Figure 1-4. Voltage Selector Switch

CAUTION

Improper voltage selection can damage the system's power supply!

2. Ensure that the power switch is in the off (out) position. Refer to your system's *Installation Information* for a view of the positions of this switch.

Getting Started

3. Connect the mouse, keyboard, video or terminal cable, and power cords to the system components, as Figure 1-5 shows.

CAUTION

The system auxiliary AC outlet is limited to 2 Amps at 115 Volts (1 Amp at 230 Volts). Plug higher-amperage video monitors into a wall receptacle.

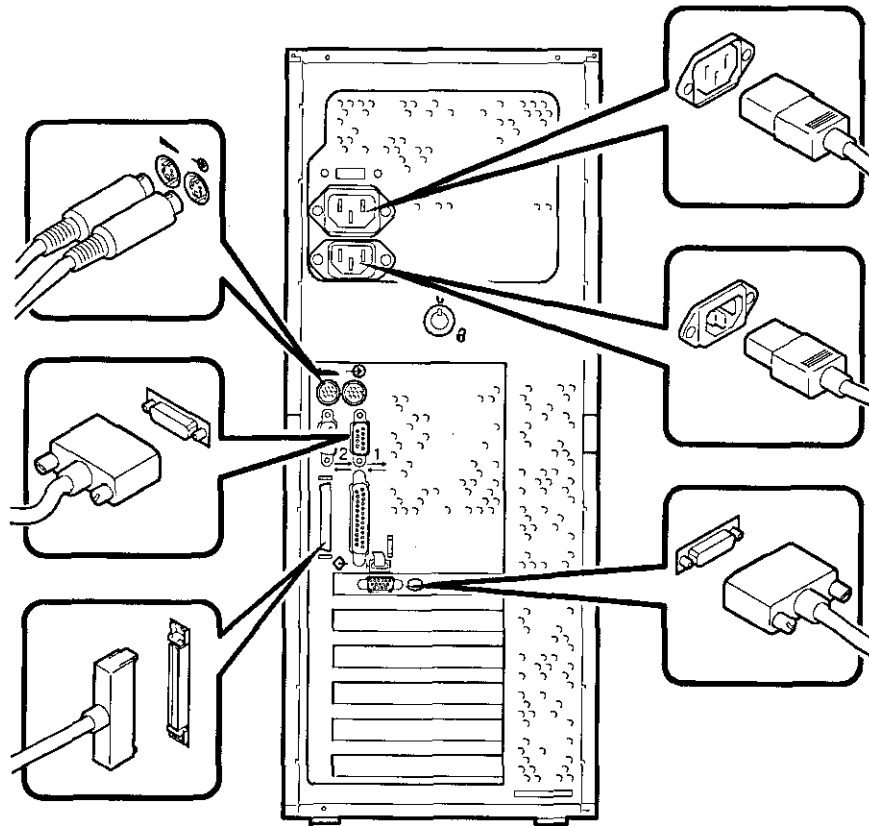

Figure 1-5. Connecting Cables and Power Cords

4. If you have an external SCSI (small computer system interface) device or SCSI storage box, connect the SCSI cable to the SCSI port on the rear of the system. See the SCSI Termination section in Chapter 3.

Network Connection

If you ordered a system with an optional network module, connect your network interface cable to the appropriate port on your network module. Using the console software, you must select which of the two network ports will be used. See Appendix A, Console Commands, for detailed information.

Starting Your System

Perform the following steps in the order outlined to start (boot) your Digital AlphaServer 400 Series system:

1. Turn on the system unit power, monitor power, and any external devices. Figure 1-6 shows the location of the system unit power button.

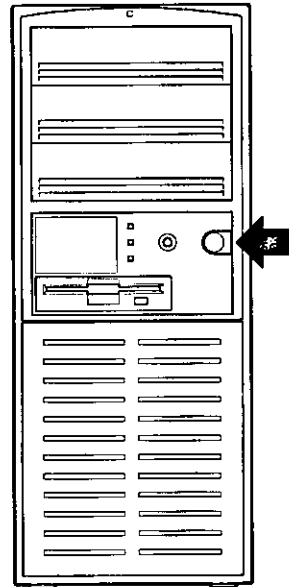

Figure 1-6. Starting Your System

2. You might need to adjust the monitor/terminal contrast and brightness to obtain a readable screen display. If you are using a console terminal connected to SLU1 and no screen display is visible, press Return three or four times. A >>> prompt should then display. Type `set console serial`. (Otherwise, refer to the information supplied with your monitor for further instructions.)
3. Allow your system to complete any power-on self tests and device initialization messages. (This takes approximately 1 minute.) If you are using the OpenVMS or OSF/1 operating systems, and the `auto_action` environment variable is set to "boot,"

Getting Started

the system starts as soon as the self tests have completed (less than 2 minutes). If you are using the Microsoft Windows NT Server operating system and autoboot is enabled, the system starts after a countdown expires (default is 10 seconds).

Preloaded Operating System Software

If you ordered a DEC OSF/1 or OpenVMS version of the AlphaServer 400 Series system, your operating system came preloaded. If you ordered a Microsoft Windows NT Server version, the operating system is not preloaded. Disk 0 on the first SCSI bus, however, is partitioned and formatted so that you can immediately install the operating system.

Depending on how the environment variables are set, your system shows one of the operating system-specific displays discussed next, after the self tests have completed successfully.

☞ For more information on environment variables, see Appendix A, Console Commands.

Microsoft Windows NT Server

If you ordered a system with the Microsoft Windows NT Server operating system, you will see the following display after power-on and initialization:

```
ARC Multiboot Alpha AXP Version 3.5-13
Copyright (c) 1993 Microsoft Corporation
Copyright (c) 1993 Digital Equipment Corporation
```

Boot menu:

```
Boot Windows NT
Boot an alternate operating system
Run a program
Supplementary menu...
```

Use the arrow keys to select, then press Enter.

If autoboot is enabled, a countdown timer (default 10 seconds) is displayed. Booting occurs when the timer expires.

DEC OSF/1

If you are using the DEC OSF/1 operating system, you see either a >>> prompt (if *auto_action* is set to Halt) or the system proceeds to boot DEC OSF/1 (if *auto_action* is set to Boot) when you power on your system.

☞ For more information, refer to your operating system documentation.

OpenVMS

If you are using the OpenVMS operating system, you will either see a >>> prompt (if *auto_action* is set to Halt) or the system will proceed to boot OpenVMS (if *auto_action* is set to Boot) when you power on your system.

☞ For more information, refer to your operating system documentation.

Switching Console Firmware

To switch from the ARC console (used with the Microsoft Windows NT Server operating system) to the SRM console (used with the OpenVMS and DEC OSF/1 operating systems), follow these steps from the Boot menu:

1. Select Supplementary menu...
2. Select Set up the system...
3. Select Switch to OpenVMS or OSF console
4. Select Switch to OpenVMS
-or-
Select Switch to OSF
5. Select Setup menu...
6. Power-cycle the system to implement the change. (Leave the system off for at least 20 seconds.)

To switch from the SRM console to the ARC console, follow these steps from the SRM prompt:

1. >>>set os_type nt
2. Power cycle the machine. (Leave the system off for at least 20 seconds.)

If No Operating System Is Installed

☞ If an operating system was not *preloaded* on your system, refer to Appendix F and your operating system documentation for information on performing an installation.

Getting Started

Turning Off Your System

Before turning off your system, make sure to save and close all open files. If you turn the system off without saving and closing files, you might lose some or all of your work.

Perform the following steps to turn off your system:

1. Close any application data files you have open as well as any applications you have running. Most application programs prompt you to save the information before closing.
2. Shut down the operating system with the appropriate command from the table below:

Operating System	Action
Microsoft Windows NT Server	From the Program Manager File Menu, choose Shutdown. Choose the OK button to confirm.
DEC OSF/1	Type the following from a superuser account: <code>shutdown -h now</code>
OpenVMS	Type the following from a privileged account: <code>@sys\$system:shutdown</code>

3. Wait for the operating system to complete the shutdown process. For OpenVMS and DEC OSF/1, the SRM console prompt (>>>) is displayed. Microsoft Windows NT Server displays a window indicating it is safe to turn off or restart the system.
4. Do not turn off power to your system and peripherals until the shutdown sequence has completed.

Computer Security

Your Digital AlphaServer 400 Series system includes several security features. See your operating system documentation for more information on the availability and use of these options.

Chassis Lock

To avoid theft of internal components, your Digital AlphaServer 400 Series system comes with a chassis key lock, which is located on the back of your system box. When this lock is in the locked position, no one else can open the system box. Store the key in a safe place.

Security Loop

Your system comes with a built-in security loop, which discourages theft of your system unit.

Passwords

You can set your system for screen saver and pause screen passwords.

System Overview

Introduction

This chapter describes the Digital AlphaServer 400 Series system hardware components, including the motherboard, PCI (peripheral component interconnect) architecture, keyboard, front panel, and rear panel.

Motherboard

Your Digital AlphaServer 400 Series system uses high-performance Alpha architecture CPU modules.

The system box has the following features:

- Three storage bays for half-height 5.25-inch devices.
- Floppy disk controller that supports two floppy drives or one floppy and one tape drive.
- SCSI-2 (small computer system interface) controller with both internal and external busses that support up to seven SCSI devices.
- Two slots for PCI options, three slots for ISA (industry-standard architecture) options, and one additional slot that can be used for either option.
- Keyboard and mouse ports.
- Two serial ports.
- One enhanced bidirectional parallel port.



Refer to Appendix C, Technical Specifications, for additional information.

PCI Architecture

Your system's PCI architecture represents the latest advances in local bus technology. The Digital AlphaServer 400 Series system PCI architecture delivers maximum performance by providing a wider data path, greater speed, and improved expandability. Now, you can

System Components

move ISA bus peripheral controller functionality over to the PCI bus with available PCI peripheral controllers. The result is faster data transfers for devices such as SCSI controllers and high-end video adapters—a critical advantage when you are running graphic- and I/O-intensive software.

PCI local bus features include:

- Highest performance in the market today.
- Best expandability for high-performance peripheral devices.
- Support for multiple bus masters.
- 32-bit data transfer at 132 MB (megabytes) per second (peak).
- PCI-to-ISA bridge capability that allows you to use commonly available ISA options.

SCSI Controller

The Digital AlphaServer 400 Series system uses a PCI-based embedded SCSI-2 controller that controls up to seven SCSI peripherals such as hard disk drives, CD-ROM (compact disc read only memory) drives, and tape drives.

Keyboard

Your system comes equipped with a 101-key enhanced keyboard that allows you to communicate with your system by entering data or commands. (Notice that some European language keyboards have 102 keys.) You can adjust the angle of the keyboard for your comfort. The underside of the keyboard has feet that swing down and lock into place. Refer to Figure 2-1 and Table 2-1 for information on keyboard key groups and functions.



Refer to your operating system or application software documentation for software-specific key functions.

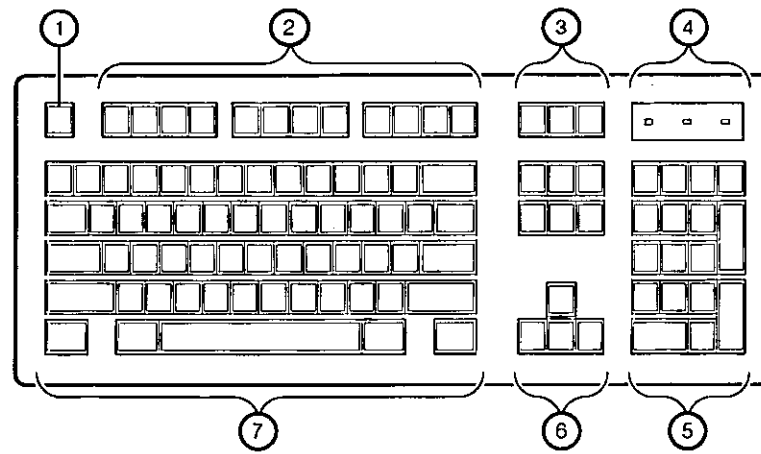

Figure 2-1. Keyboard Layout

Table 2-1. Key Groups and Functions

Figure Legend	Key, Key Group	Function
1	Escape key	This key is program specific. Its function is determined by the installed application software.
2	Function key group	These keys are program specific. Their functions are determined by the installed application software.
3	Edit key group	These keys are program specific. Their functions are determined by the installed application software.
4	Indicator lights	Indicates whether the NumLock, CapsLock, or ScrollLock has been activated.
5	Numeric keypad	These keys perform numeric functions and software-defined functions, including cursor control. The NumLock key allows you to toggle between the numeric functions and software-defined functions.
6	Cursor control key group	These keys control the movement of the highlighted cursor on the monitor screen.
7	Alphanumeric key group	These typewriter-specific keys feature auto-repeat capability. If you press and hold down any of these keys, the keystroke repeats automatically until released.

System Components

System Front View

Figure 2-2 is a front view of the system showing the location of the controls and indicators. Table 2-2 describes these items.

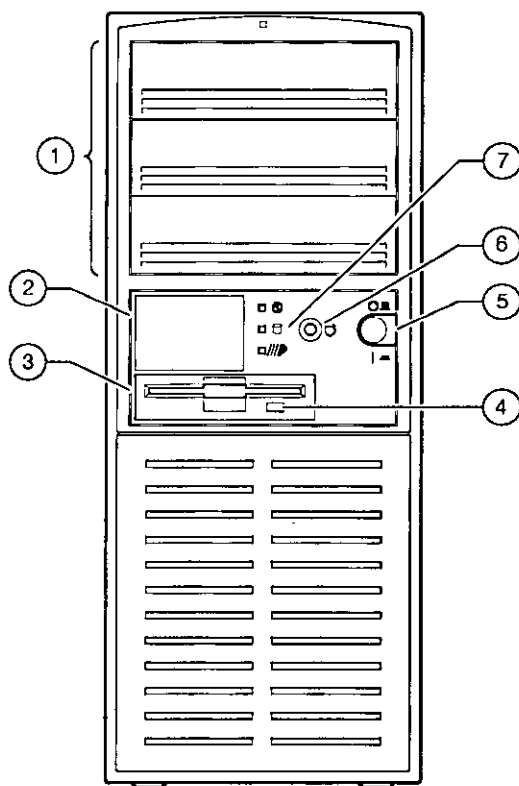

Figure 2-2. Front Controls and Indicators

Table 2-2. Front Controls and Indicators

Figure Legend	Control or Indicator	Function
1	Drive bays	Location of three upper 5.25-inch drive bays.
2	Hard drive	Location of hidden 3.5-inch drive bay.
3	Floppy drive	Location of 3.5-inch diskette drive.
4	Floppy eject button	Releases a 3.5-inch diskette from the floppy diskette drive.
5	Power On/Off button	Turns AC power on and off.
6	Halt/Reset button	When set to Halt, this button is operating system-specific. See your operating system documentation. When set to Reset (default), this button resets the system and causes the self test to run. See Appendix C, Technical Specifications, for setting the Halt/Reset jumper.
7	Indicators	Indicators from top to bottom are as follows: <ul style="list-style-type: none"> • Power indicator lights when the system is on. • Hard disk drive indicator lights when a hard disk drive is in use. • The lower indicator is not used.

System Components

System Rear View

Figure 2-3 shows the rear connectors and lock. Table 2-3 lists the rear connectors and lock and describes their functions.

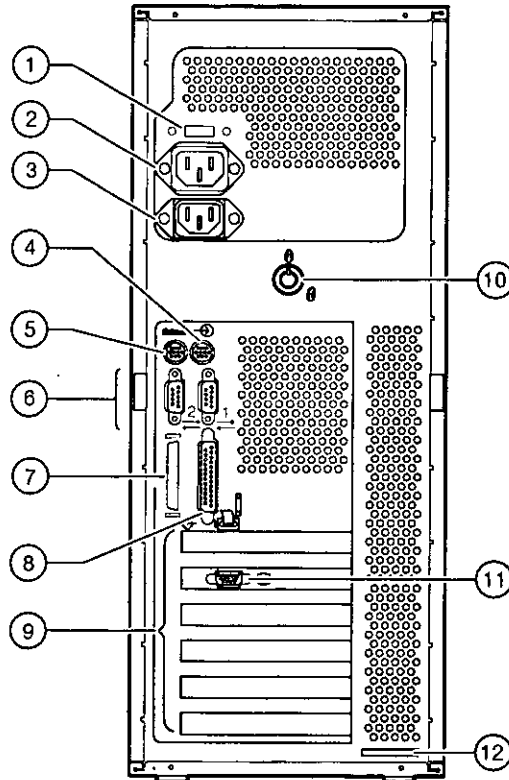

Figure 2-3. Rear Connectors

Table 2-3. Rear Connectors

Figure Legend	Connector	Function
1	Voltage selector switch	Allows you to set your system to work with 115 or 230 Volts AC power.
2	Monitor power connector	Connects a monitor to AC power. <i>If your monitor consumes more than 2 Amps at 115 Volts (1 Amp at 230 Volts), connect it directly to your wall outlet.</i>
3	AC power connector	Connects the system to AC power.
4	Mouse connector	Connects a PS/2-compatible mouse.
5	Keyboard connector	Connects a 101- or 102-key keyboard.
6	Serial port connectors	Connects serial devices.
7	SCSI connector	Provides the interface between the system unit and external SCSI devices.
8	Parallel port connector	Allows you to connect an industry-standard parallel printer.
9	Expansion board slots	Allow you to install up to two full-size PCI, up to three full-size ISA, and one additional PCI or ISA expansion boards. See Chapter 3 for the layout of these connectors.
10	System (chassis) lock	Locks outside panels.
11	Video port (on option module)	Provides the interface between video/graphics expansion module (option) and the supported monitor.
12	Security loop	Attaches security lock or cable.

Installing System Options

Introduction

This chapter explains how to install optional memory, expansion boards, and drives inside your Digital AlphaServer 400 Series system.

Removing the Side Panels

To remove the side panels, perform the following steps:

1. Turn off your system and all peripheral devices.
2. Unplug the power cord and remove the monitor power cord (if connected) and video cable.
3. Wait at least 20 seconds, to allow time for the power supply capacitors to safely discharge.
4. Unlock the side panels. To unlock the side panels, turn the key clockwise to a horizontal position (Figure 3-1).

CAUTION

To avoid system damage from static discharge, touch bare (unpainted) metal on the system before you touch anything inside the system.

5. Slide the panels to the rear of the system unit (Figure 3-1), and remove them.

Expanding Your System

NOTE

If you are installing or removing drives, you must remove both side panels. Otherwise, remove only the left side panel.

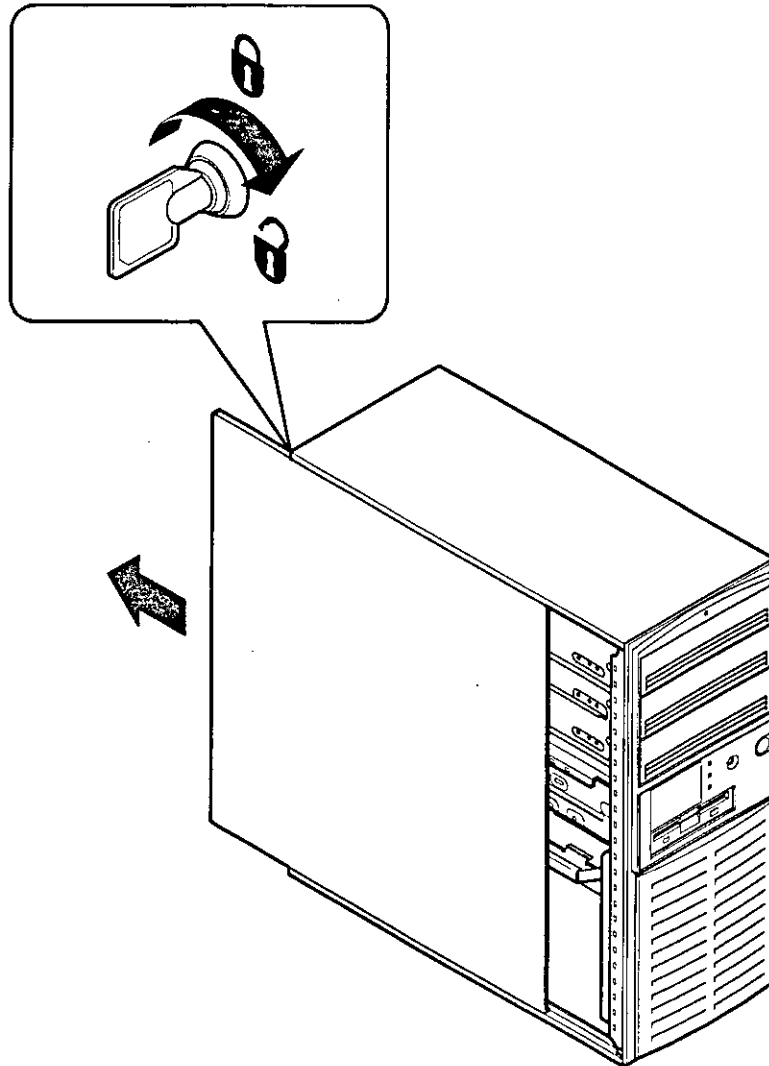

Figure 3-1. Unlocking and Removing Left Side Panel

System Unit Components

Figure 3-2 shows the location of the Digital AlphaServer 400 Series system unit components. Table 3-1 lists the system unit components.

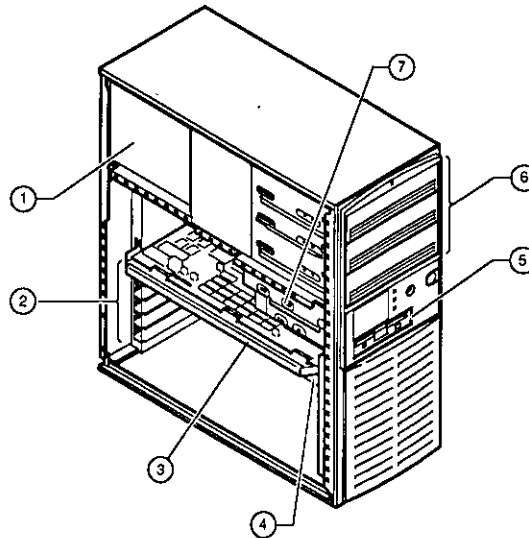

Figure 3-2. System Unit Components

Table 3-1. System Unit Components

Figure Legend	Component
1	Power supply
2	Two PCI, three ISA, and one combination PCI/ISA expansion slots
3	CPU module
4	Motherboard
5	One 3.5-inch diskette drive
6	Three 5.25-inch half-height drive bays
7	Hidden 3.5-inch half-height drive bay

Expanding Your System

Motherboard

Figure 3-3 shows the location of the motherboard components. Table 3-2 lists the motherboard components.

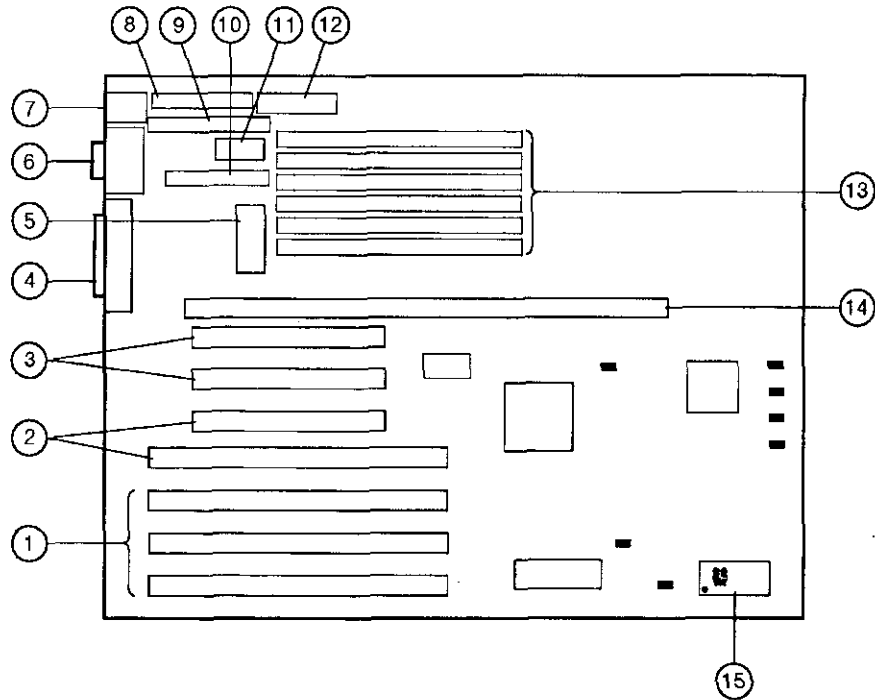

Figure 3-3. Motherboard Components

Table 3-2. Motherboard Components

Figure Legend	Components
1	ISA expansion slots
2	Combination PCI and ISA expansion slot
3	PCI expansion slots
4	External SCSI connector and bidirectional parallel port
5	Power connector (+3.3 Volts)
6	Serial ports
7	Mouse and keyboard connectors
8	FDC connector
9	Internal SCSI connector
10	Unused
11	Power connector (+5 Volts)
12	Power connector (+5, -5, +12, and -12 Volts)
13	Six SIMM connectors
14	CPU module connector
15	Realtime clock

Installing Additional System Memory

Adding more memory allows your system to run larger, more memory-intensive software more quickly. You can increase your system's memory up to 192 MB.

You can add 16-MB, 32-MB, or 64-MB memory options. These memory options are pairs of single in-line memory modules (SIMMs); a 16-MB option consisting of two 8-MB SIMMs, a 32-MB option consisting of two 16-MB SIMMs, or a 64-MB option consisting of two 32-MB SIMMs. SIMMs are *always* added in pairs into one of three available memory banks. The system requires 36-bit SIMMs that have an access time of 70 ns.

Memory Configurations

SIMMs are added in any of three banks, with each bank having two slots (Figure 3-4).

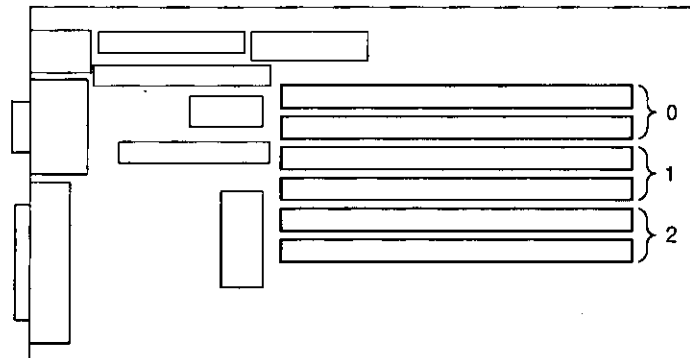

Figure 3-4. Memory Banks

Adding Memory Modules

To add a pair of memory modules (SIMMs), perform the following steps:

1. Turn off your system. Disconnect any external devices and unplug the power cord from the wall outlet. Unplug the power cord and monitor cord from the back of the system unit.
2. Unlock and remove the left side panel.
3. Install the SIMM into the socket at a 45-degree angle (Figure 3-5). Be sure that the notch is oriented as shown. Rock the SIMM gently until it is seated evenly into the bottom of the socket. Tip the SIMM upright until both the retaining clips at the ends of the socket engage.
4. Replace and lock the left side panel.
5. Connect the power cord and monitor cord to the back of the system unit.
6. Connect any external devices and plug the power cord into the wall outlet.

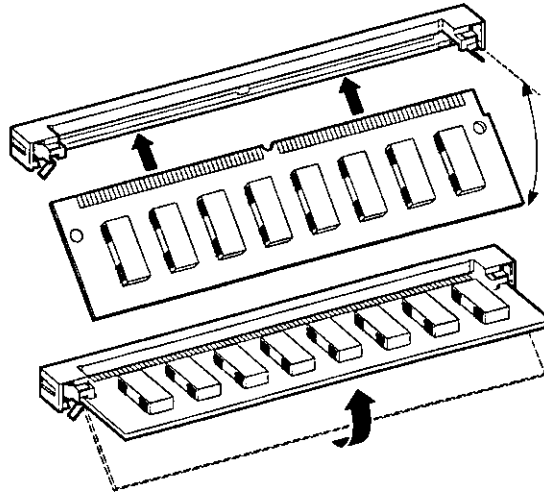

Figure 3-5. Installing a SIMM

Installing Expansion Boards

The Digital AlphaServer 400 Series system features two PCI slots, three ISA slots, and one combination PCI and ISA slot.

NOTE

The SRM console for DEC OSF/1 and OpenVMS systems assigns available IRQs to PCI devices. IRQs are considered available if they are not assigned to ISA devices in the console's configuration database. Use the ISACFG console to maintain the configuration database.

☞ For further information on IRQs, refer to the ISACFG command in Appendix A.

☞ Refer to your option module documentation for instructions on configuring a PCI or an ISA option module.

To install an expansion board, perform the following steps:

1. Turn off your system. Disconnect any external devices and unplug the power cord from the wall outlet. Unplug the power cord and monitor cord from the back of the system unit.
2. Unlock and remove the left side panel.
3. Unscrew and remove the metal filler plate.
4. Insert the new expansion board into the socket in the motherboard. Push the board firmly into the socket (Figure 3-6).

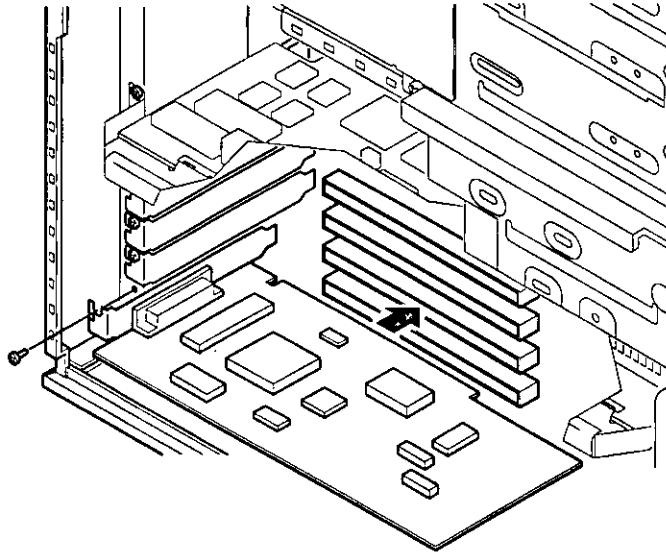

Figure 3-6. Installing an Expansion Board

5. Replace the screw to secure the module.
6. Replace and lock the left side panel.
7. Connect the power cord and monitor cord to the back of the system unit. Connect any external devices and plug the power cord into the wall outlet.
8. For ISA options added to DEC OSF/1 or OpenVMS systems, run the configuration utility (ISACFG from the SRM console prompt, >>>). See Appendix A, Console Commands, for more information on this utility.



For more information on operating-system-specific options, refer to your operating system documentation.

Adding Mass Storage Devices

Your system has two drive bay areas: the upper drive bay and the lower drive bay. You can install mass storage devices such as hard disk drives, floppy diskette drives, CD-ROM drives, and tape backup drives in these drive bay areas:

- Upper drive bay area. This area has room for three 5.25-inch half-height devices. Each drive bay is equipped with a removable panel to accommodate devices requiring front panel access.

The bottom two bays of this area can be used to mount one full-height drive. The drive rails are removable to accommodate a full-height device.

- Lower drive bay area. This area has a drive bay assembly that holds a 3.5-inch floppy diskette drive (standard on all Digital AlphaServer 400 Series systems) and one hidden (nonaccessible from the front) 3.5-inch half-height device. This hidden bay is typically used for mounting the system's primary hard disk drive.

Expansion Brackets

You can install half-height devices in any of the three positions in the upper drive bay area. To install a 3.5-inch device in the upper drive bay, install the drive expansion brackets onto the device.

NOTE

Be sure to use the brackets that came with the system, rather than those that came with the drive.

SCSI Bus Length

The total SCSI bus length, including internal cables and etch on the motherboard as well as the external cables between storage enclosures and the cables inside the storage enclosures, must not exceed 3 meters (9.8 feet) for fast SCSI operation or 4 meters (13.1 feet) for slow SCSI (5 MB/second) operation. The Digital AlphaServer 400 Series system's internal SCSI length is 1.5 meters (4.9 feet), leaving 1.5 meters (4.9 feet) available for fast SCSI use (2.5 meters [8.2 feet] for external slow SCSI use).

SCSI Addresses

Before installing a SCSI drive, you must either set or verify the setting of the drive's SCSI address (SCSI ID). Digital recommends that you use Table 3-3 as a guide to the selection of an address for your SCSI drive.

Table 3-3. SCSI Address Recommendations

SCSI Address (ID)	Device (Drive) Recommended
0	System disk (where your operating system resides)
1	Expansion/hard disk drive
2	Expansion/hard disk drive
3	Expansion/hard disk drive
4	CD-ROM drive
5	Expansion module or SCSI tape drive
6	Expansion
7	Host adapter (SCSI controller)

SCSI Termination

The Digital AlphaServer 400 Series system has a built-in SCSI bus that can be connected to both internal (inside the system box) and external SCSI peripherals. Termination is required at both the internal and external ends.

Internal Termination

The internal SCSI bus cable contains the proper termination. If you add SCSI peripherals inside the system box, make sure that any termination on the new peripheral is disabled. Refer to the appropriate drive manual to disable the new peripheral's termination.

External Termination

When no external peripherals are present, use the console firmware to terminate the external portion of the SCSI bus. If you use the SRM console, type `>>> set Control_SCSI_term internal`. If you use the ARC console, go the *Machine specific setup menu* . . . and select *set SCSI termination to internal*. This is the default setting.

If you add external SCSI peripherals, use the SRM console to set the value of the environment variable `control_scsi_term` to external, or use the ARC machine specific setup menu to set SCSI termination to external. Make sure that the last peripheral on the external SCSI bus is properly terminated.

CAUTION

Failure to properly set up the SCSI termination can result in loss of data or damage to the file system.



See Appendix A, Console Commands, for more details.

Expanding Your System

Installing Devices in the Upper Drive Bay Area

To install a device in the upper drive bay area, perform the following steps:

1. Turn off your system and unlock and remove the side panels, as described earlier in this chapter.
2. Carefully remove the plastic filler panel (Figure 3-7). If no drive is present in the slot that is to be used, you can remove the panel by pushing it out from the inside with a Phillips screwdriver inserted through one of the screw holes in the side of the drive bay.

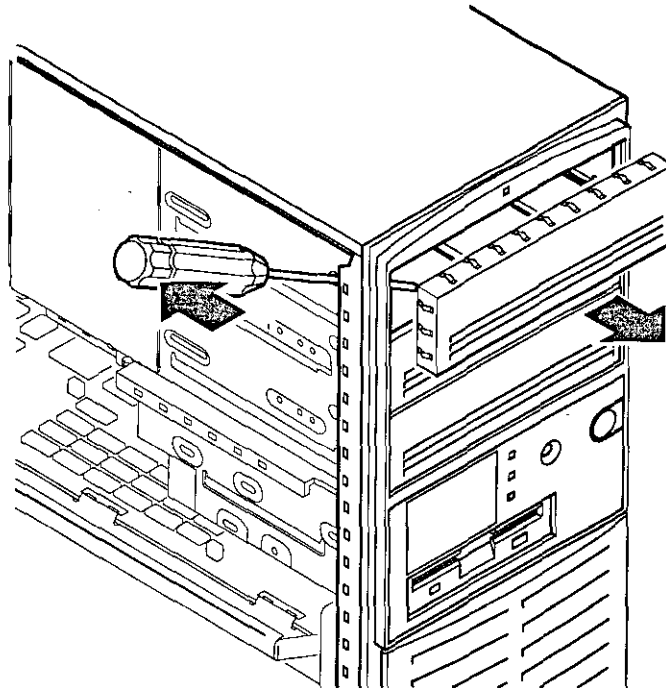

Figure 3-7. Removing Plastic Filler Panel from the Upper Drive Bay

3. Refer to your drive documentation to configure the drive. If the drive is a SCSI drive, you must select a SCSI address and make sure that SCSI termination is disabled. Term power should be enabled. Record the SCSI address you used in Appendix G, Equipment Log.
4. Remove the metal plate, as Figure 3-8 shows. The top of the plate is hooked behind a rail, and the bottom of the plate is held by a screw. To improve access, remove the metal plate from the other side of the system.

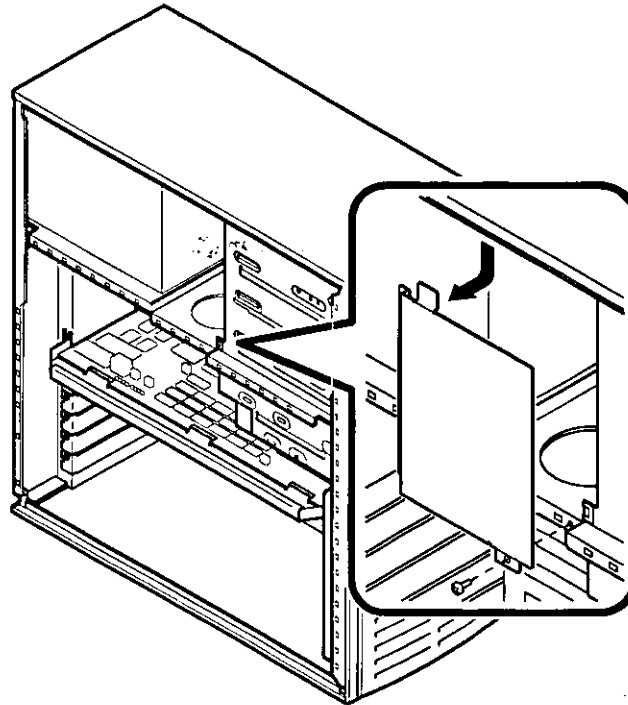

Figure 3-8. Removing the Metal Plate

5. If you are installing a 3.5-inch device, add the 3.5- to 5.25-inch exchange brackets, as Figure 3-9 shows. Fasten the drive with the screws provided.

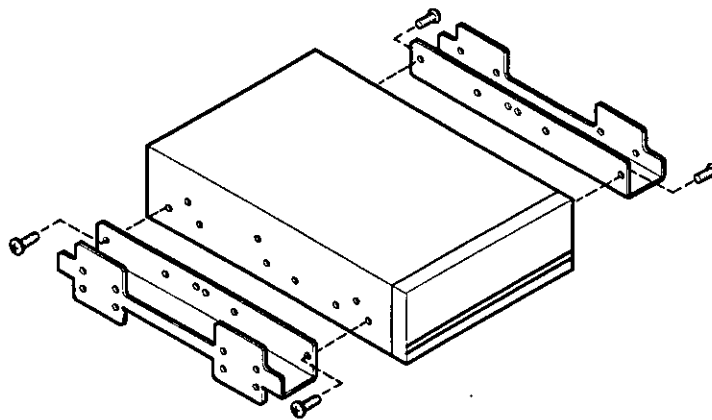

Figure 3-9. Exchange Bracket Mounting

Expanding Your System

6. Insert the new device into the drive bay from the front (Figure 3-10).
7. Secure the device with two screws on each side. Use the three front mounting holes as follows: H for hard drive; T for tape drive; and F for floppy or CD drive.

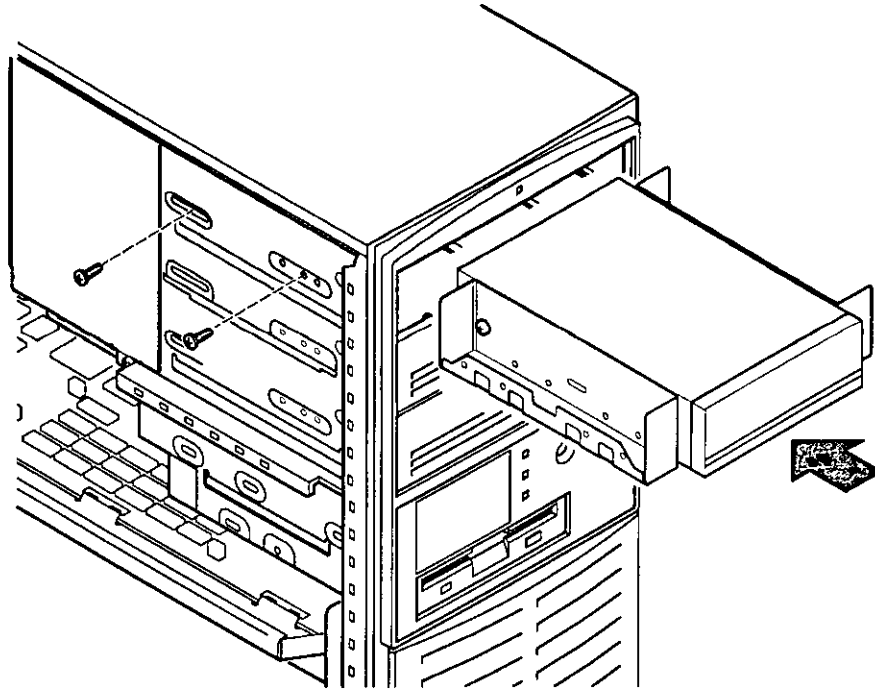

Figure 3-10. Inserting a Device into the Upper Drive Bay

8. Connect the SCSI cable to the device. Figure 3-11 shows a cabling configuration using one floppy diskette drive and three SCSI drives. If you have a SCSI tape drive, it will connect to the SCSI cable. If you have an FDC tape drive, it will connect to the FDC cable (the same cable used by the floppy diskette drive).

Be sure that the cable is connected with the correct orientation. All cables and most connectors are keyed so that you cannot connect them backwards. If your drive is not keyed, you must connect pin 1 of the cable to pin 1 of the socket.

Pin 1 of the cable is on the edge with the colored stripe or pattern. Pin 1 of the socket is marked with either a tiny number "1" at one end of the socket or with a tiny number "1" or "2" printed on the circuit board near one end of the socket.

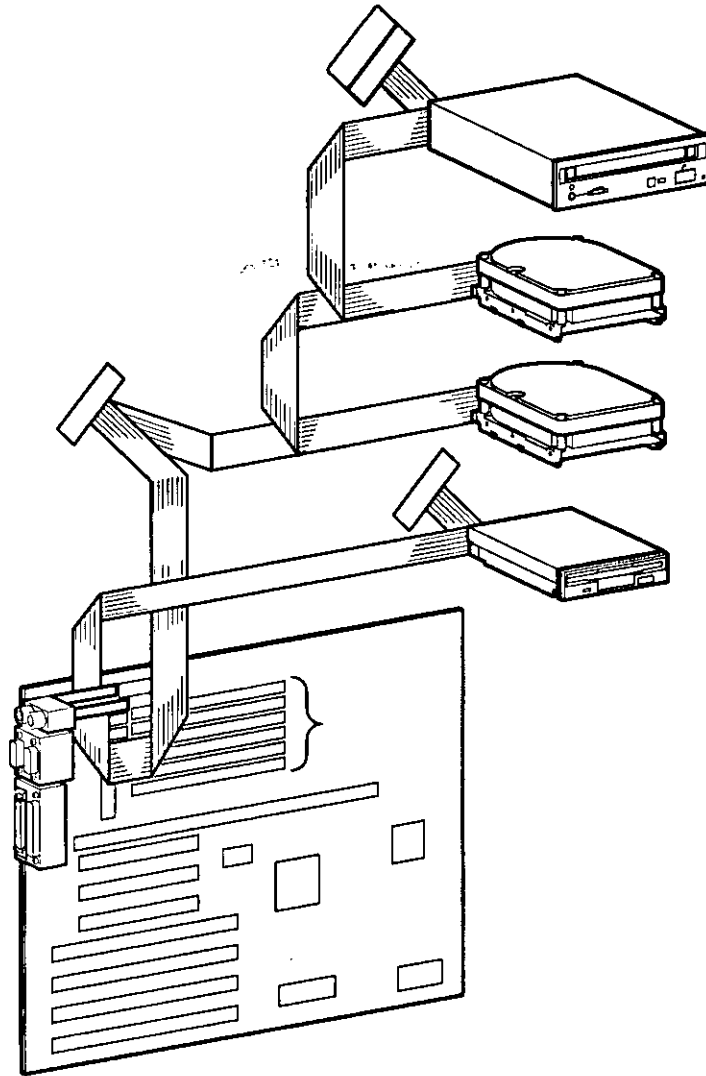

Figure 3-11. SCSI and FDC Cable Configuration

Expanding Your System

9. Connect a power cable to the device. Figure 3-12 shows the cables from the power supply.

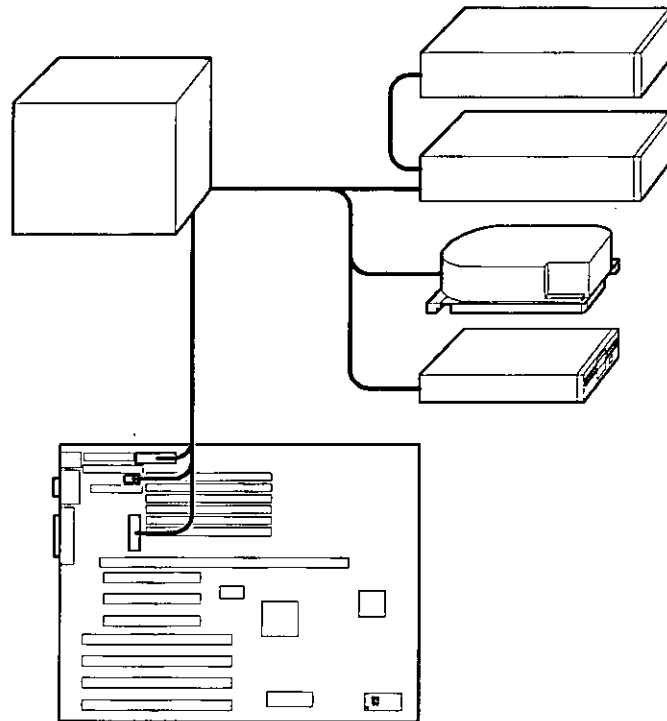

Figure 3-12. Power Cable Configuration

10. Replace the metal plate that you removed in step 4.
11. Replace and lock the side panels.
12. Connect the power cord and monitor cord to the back of the system unit.
13. Connect any external devices and plug the power cord into the wall outlet.

Installing Devices in the Lower Drive Bay Area

The lower drive bay area holds two 3.5-inch devices, a diskette drive, and, typically, a hard disk drive. To upgrade the devices in the lower drive bay area, you must remove the entire drive bay assembly from your system and then remove the devices from the assembly and install the new devices. Perform the following steps:

1. Turn off your system. Disconnect any external devices and unplug the power cord from the wall outlet. Unplug the power and monitor cords from the back of the system unit.
2. Unlock and remove the left side panel, as described earlier.
3. Remove the cables from the devices in the lower drive bay. Note the position of the cables so that you can reconnect them to the correct devices later.
4. Lift the retaining clip at the rear top of the drive bay assembly and slide the assembly to the rear of the system unit (Figure 3-13).

CAUTION

Be sure to support the drive bay assembly so that it does not fall and damage the circuit boards.

Expanding Your System

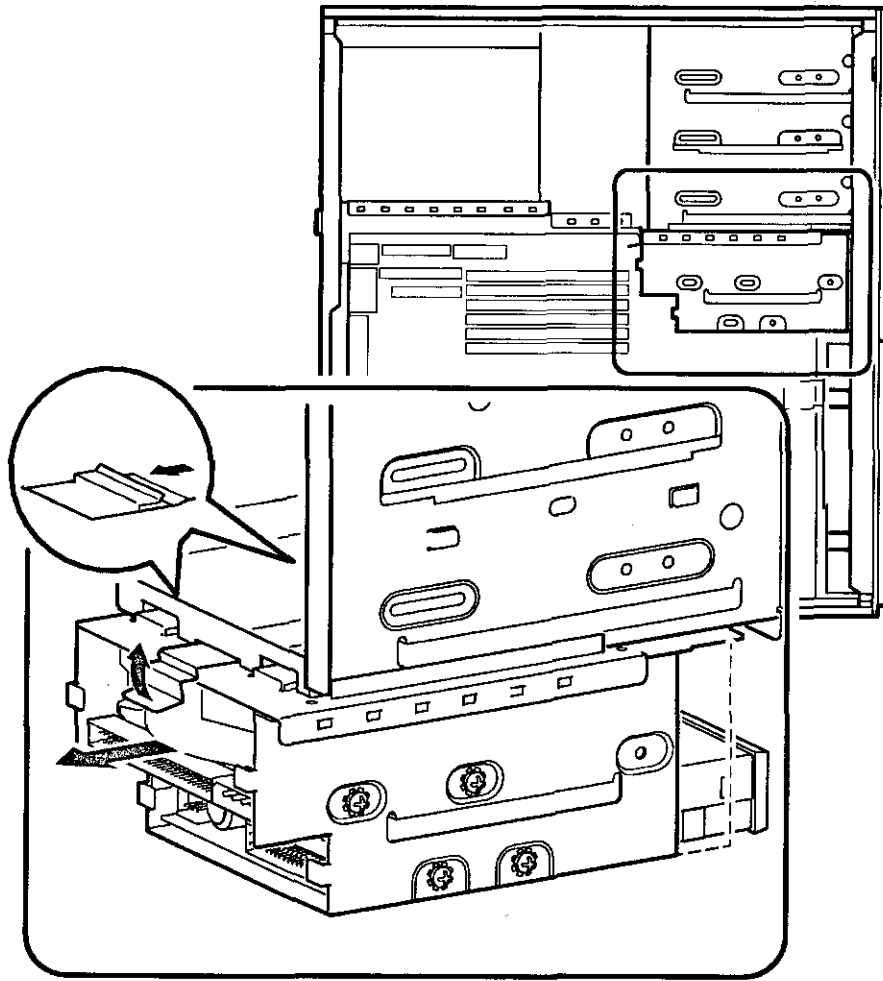

Figure 3-13. Removing the Lower Drive Bay Assembly

5. Remove a device by removing the screws on the side and sliding the device out of the lower bay assembly (Figure 3-14).

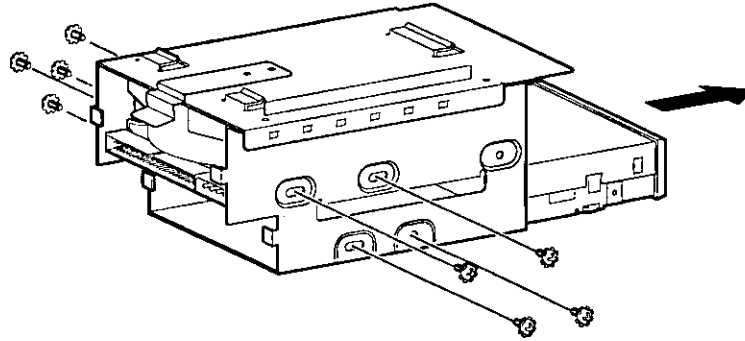

Figure 3-14. Removing the Lower Drive Bay Devices

6. Slide the drive into the drive bay assembly and secure it with screws.

CAUTION

Be sure to use the screws that came with the drive. Other screws may be too long and could damage the internal mechanism of the drive.

7. Replace the lower drive assembly in the system by sliding it forward until the retaining clip latches.
8. Reconnect the data and power cables to the drives.

CAUTION

Loosely hanging cables can block air flow and cause system overheating. Use the provided cable clips to fasten the cables to the inside top of the processor area.

9. Replace and lock the left and right side panels.
10. Connect the power cord and monitor cord to the back of the system unit.
11. Connect any external devices and plug the power cord into the wall outlet.

Troubleshooting

Introduction

This chapter describes initial and system troubleshooting as well as error beep codes and diagnostic LEDs (light emitting diodes).

-  Refer to the documentation supplied with additional options if you are experiencing problems with specific options that you have installed.

Initial Troubleshooting

Follow these general procedures to troubleshoot your Digital AlphaServer 400 Series system initially:

1. Check that the power indicators are on and that the fan is running.
2. Check the power indicator on the monitor. Also, check the monitor, keyboard, and mouse cables to ensure that they are connected and seated properly.
3. Press the Halt/Reset button. If your system fails to boot, turn it off, wait 20 seconds, and then turn it back on.
4. Make sure that all cables and connections are secure.
5. If the operating system has not loaded after two minutes, see the diagnostic LEDs section of this chapter.
6. Contact Digital Services or your service provider for software- or hardware-related problems.

NOTE

If you need to return a failed component, pack it in its original container and return it to Digital Equipment Corporation or your service provider.

Troubleshooting

Equipment Log

For your convenience, Appendix G, Equipment Log, includes a form on which you can record all model numbers and serial numbers of your hardware components (system unit, monitor, keyboard, and mouse) and system hardware configuration information (CPU, memory size, drive size, ports, and so on).

General Troubleshooting

Tables 4-1 through 4-3 list how to identify and solve problems that could occur with your system, disk drive, and monitor.

Table 4-1. System Troubleshooting

Problem	Possible Cause	Action
Power indicator not on.	System is not plugged in.	Turn off the system, plug it in, and then turn it back on again.
	No power at the wall outlet.	Use another wall outlet.
	Power supply failure.	Contact your service representative.
	Internal power supply cables not reconnected after installing options.	Reconnect cables.
Power is on, but there is no screen display.	Brightness and contrast controls are not correctly set.	Adjust the brightness and contrast controls.
	Monitor is off.	Turn on the monitor.
	Monitor cable or power cord is incorrectly installed.	Check all monitor connections.
	Configuration error.	Refer to the video module documentation for more information.
	Monitor is defective.	Try another monitor.
	Defective video controller module.	Replace the video module.

Table 4-1. System Troubleshooting (continued)

Problem	Possible Cause	Action
System does not boot.	Operating system software is not installed on the hard disk drive.	Install the appropriate operating system.
	System cannot find the boot device.	<p>Check the system configuration for correct device parameters.</p> <p><i>OSF/1 and OpenVMS:</i> Use the SRM show config and show device commands. (See Appendix A, Console Commands.) Use gathered information to identify target devices for boot command and verify that the system sees all installed devices.</p> <p><i>Windows NT:</i> Use the ARC console to display the available boot devices. First, from the Boot menu select Supplementary menu..., then select List available boot devices. Verify that the target boot device is listed.</p>
	Environment variables incorrectly set.	<p>Check and set the environment variables, if necessary.</p> <p><i>OSF/1 and OpenVMS:</i> Use the SRM console show envar and set envar commands to check and set the values assigned to boot-related variables such as <i>auto_action</i>, <i>bootdef_dev</i>, and <i>boot_osflag</i>. (See Appendix A, Console Commands.)</p>

Table 4-1. System Troubleshooting (continued)

Problem	Possible Cause	Action
System does not boot. (continued)	<p>Environment variables incorrectly set (continued).</p> <p>Hard disk drive is not correctly formatted or the requested partition does not exist.</p> <p>The requested partition has no software.</p>	<p><i>Windows NT:</i> From the Boot menu, select Supplementary menu..., then select Setup the system..., then select Set default environment variables. (Refer to Appendix A, Console Commands.)</p> <p>Format the hard disk drive or correctly partition the hard disk drive using the supplied software.</p> <p>Install software on the requested partition.</p>
Target boot device not listed in show device, show config (SRM), or List available boot devices (ARC).	<p>Loose cables.</p> <p>SCSI drive jumpers incorrectly set.</p> <p>SCSI (small computer system interface) bus termination incorrectly set.</p>	<p>Secure all cable connections.</p> <p>Check all SCSI devices for incorrect or conflicting IDs. Refer to the hard disk drive documentation.</p> <p>Check that SCSI bus is properly terminated. Refer to Chapter 3 for more information.</p>

Table 4-1. System Troubleshooting (continued)

Problem	Possible Cause	Action
No response to keyboard commands.	Keyboard is password protected.	Enter the keyboard password, if supported by your operating system.
	Keyboard is not connected.	Connect the keyboard to the keyboard port. ¹
	Keyboard is connected to the mouse port.	Connect the keyboard to the keyboard port. ¹
No response to mouse commands.	Mouse is not connected.	Connect the mouse. ²
	Mouse is connected to the keyboard port.	Connect the mouse to the mouse port. ²
	Mouse driver not installed.	Install the appropriate mouse driver; refer to your supplied application software documentation.
	Mouse ball sticking.	Refer to the section on cleaning the mouse.

¹Turn the system off before connecting the keyboard.

²Turn the system off before connecting the mouse.

Troubleshooting

Table 4-2. Disk Drive Troubleshooting

Problem	Possible Cause	Action
Hard disk drive cannot read or write information.	Incorrect disk drive jumper settings.	Refer to the disk drive installation instructions.
	Loose or incorrectly installed cables.	Make sure that all cables are installed correctly.
	SCSI hard disk drive is not correctly formatted or partitioned.	Format and partition as required using the supplied operating system.
Floppy drive cannot read or write information.	Floppy is not formatted.	Format the floppy.
	Floppy is wrong density.	Use a floppy of the proper density for your drive.
	Floppy is worn or damaged.	Try another floppy.
	Floppy is write protected.	Slide the write-protect switch so that the hole is not visible.
	Floppy drive is empty.	Insert a floppy.

Table 4-3. Monitor Troubleshooting

Problem	Possible Cause	Action
Monitor power indicator is not on.	Monitor is turned off.	Turn on the monitor.
	Power cord is not connected.	Connect the power cord to the system or a wall outlet.
	No power at wall outlet.	Use another outlet.
	Power indicator is defective.	Contact your service representative or Digital Equipment Corporation.
Distorted, rolling, or flickering screen display, or wrong/uneven color.	Monitor incorrectly adjusted.	Adjust accordingly.
	Wrong type of monitor.	Try another monitor.
	Defective monitor.	Try another monitor.
	Monitor signal cable incorrectly installed.	Straighten any bent connector pins and then reconnect.

Error Beep Codes

Table 4-4 shows error beep codes that you may encounter while using the Digital AlphaServer 400 Series system. For example, if the SROM (serial read only memory) code cannot find any good memory, you hear a 1-3-3 beep code (one beep, a pause, a burst of three beeps, a pause, and another burst of three beeps).

Table 4-4. Error Beep Codes

Beep Code	Meaning
1-1-4	(1) The SROM code could not read the DROM (diagnostic read only memory) or flashROM headers, or (2) there was a checksum failure.
1-2-1	(1) The DROM code detected a realtime clock (BQ3287) failure, or (2) the realtime clock interrupt did not occur.
1-2-4	The SROM code detected a hard failure (for example, a Beache failure).
1-3-3	(1) The SROM code could not find 2 MB of good memory, or (2) there was no memory available.
3-2-1	The DROM code was unable to read the header of the flashROM, or the flashROM checksum failed. Therefore, the DROM code attempted to boot from the floppy. The attempt failed because of either: (1) no floppy in drive, or (2) no Alpha architecture boot block on the floppy.
3-2-3	The DROM code was directed by the position of jumper J5 to load the floppy, but there was no floppy in the drive.
3-2-4	The DROM code detected a failure with the keyboard or mouse controller.
3-3-1	The DROM code detected a hard failure. Refer to the LEDs to find exact location of failure.

Diagnostic LEDs

Your system contains eight diagnostic LED indicators located on the CPU module. The LEDs indicate errors that occur during system initialization and power-on self test (POST).

Interpreting the LED Indicator Values

Table 4-5 lists the LED indicator values and their meanings. The meanings are valid when the LEDs have stopped sequencing through tests due to an error condition.

Table 4-5. LED Codes

Indicator Values ³		Hex Value	Meaning
Bit 7	Bit 0		
● ● ● ● ● ○ ● ○	FA	Memory test 1 failure	
● ● ● ● ● ○ ○ ●	F9	Memory test 2 failure	
● ● ● ● ● ○ ○ ○	F8	Memory test 3 failure	
● ● ● ● ○ ● ● ●	F7	Memory test 4 failure	
● ● ● ● ○ ○ ● ○	F2	DROM and flashROM corrupted	
● ● ○ ● ● ● ● ○	DE	Memory test failed	
● ● ○ ● ● ● ○ ●	DD	FlashROM ID test failed	
● ● ○ ● ● ● ○ ○	DC	NVRAM (nonvolatile random access memory) test failed	
● ● ○ ● ● ○ ● ●	DB	SCSI controller test failed	
● ● ○ ● ● ○ ● ○	DA	PCI (peripheral component interconnect)/ISA (industry-standard architecture) bridge test failed	
● ● ○ ● ● ○ ○ ●	D9	Realtime clock test failed	
● ● ○ ● ● ○ ○ ○	D8	Keyboard controller test failed	
● ● ○ ● ○ ● ● ●	D7	Floppy controller, bidirectional parallel port, or serial ports test failed	
● ● ○ ● ○ ● ● ○	D6	Interrupts test failed	
● ● ○ ● ○ ○ ○ ○	D0	Power on self test passed, DROM console running	
● ● ● ○ ○ ○ ● ○	E2	Floppy load failed	
● ● ● ○ ○ ○ ○ ●	E1	Flash load failed	
○ ○ ● ○ ○ ○ ○ ○	20	Machine check occurred	
● ● ● ● ● ● ○ ○	FC	ARC console initialized (Final display)	
● ● ● ○ ○ ● ○ ●	E5	SRM console initialized (Final display)	

³ The filled-in circle (●) indicates that the LED is on, and the open circle (○) indicates off.

Console Commands

Introduction

The Digital AlphaServer 400 Series system contains two console subsystems: advanced RISC computing (ARC) firmware that supports the Microsoft Windows NT Server operating system, and system reference manual (SRM) firmware that supports the DEC OSF/1 and OpenVMS operating systems. The console firmware resides in 1 MB (megabyte) of flashROM on the system board. FlashROM memory can be updated in the field.

This appendix gives a basic description of each console's commands.

ARC Console

The ARC console supports the use of the Microsoft Windows NT Server operating system. The ARC console uses a menu interface. When a Digital AlphaServer 400 Series system is powered on, initialization is performed. During initialization, the firmware checks the information stored in the nonvolatile memory. If the information is unreadable or inconsistent, a warning message is displayed. The warning message identifies the areas that must be fixed prior to booting Microsoft Windows NT Server. A menu similar to the following displays after initialization:

```
ARC Multiboot Alpha AXP Version 3.5-13
Copyright (c) 1993 Microsoft Corporation
Copyright (c) 1993 Digital Equipment Corporation
```

Boot menu:

```
  Boot Windows NT
  Boot an alternate operating system
  Run a program
  Supplementary menu...
```

Use the arrow keys to select, then press Enter.

Console Commands

Commands You Need to Know

Display Hardware Configuration

The Display hardware configuration command is located in the Supplementary menu. Use this command to display information about:

- Devices that were detected (and are supported) by the ARC console
- Processor revision and speed, and physical memory size
- Video option detected
- PCI slots including vendor, revision, and device type

Set Default Environment Variables

The Set default environment variables command is located in the Setup menu. Use this command to specify the location of the default system partition. For example, when the partition is on a SCSI hard disk, you are prompted for the SCSI bus number, SCSI ID of the drive, and the partition number.

Set Default Configuration

The Set default configuration command is located in the Setup menu. Use this command to select:

- Monitor resolution.
- Floppy drive capacity. (You must change the Default value of 2.88 MB to 1.44 MB for this system.)
- Keyboard language.
- SCSI controller (Host) ID.

Manage Boot Selection Menu

You reach the Boot selection menu by selecting Manage boot selection menu from the Setup menu. Use the boot selection menu to add, change, check, delete, dump (list), and rearrange boot selections.

Initially, select Add a boot selection. You are then prompted to select:

- System partition for this boot selection. (The partition defined by the Set default environment variables command must be one of your choices.)
- Osloader directory and name.
- Whether or not the operating system is in the same partition as the osloader.

- Operating system root directory.
- Name (identifier) for this boot selection.
- Whether or not the debugger should be initialized at boot time.

After you have added a boot selection, use the Check boot selections command to perform verification testing of the selections. If an error is detected, you are prompted to ignore, delete, or change the boot selection.

Machine Specific Setup

You reach the Machine specific setup menu from the Setup menu. Use this menu to control PCI parity checking, which is by default set to on, and SCSI termination of the external portion of the SCSI bus, which is by default set to internal.

Boot "boot selection identifier"

The Boot command is the first selection in the Boot menu. Use this command to boot Windows NT using the default boot selection identifier (which is specified in the Boot selection menu).

Boot an Alternate Operating System

The Boot an alternate operating system command is located in the Boot menu. Use this command to select a boot selection identifier that is different from the default selection. For example, you can have multiple versions of Microsoft Windows NT Server installed, each with its own unique boot selection identifier, and use this command to select the version that you want to boot.

Other Commands of Interest

Setup Autoboot

The Setup autoboot command is located in the Setup menu. Use this command to enable automatic booting of the system. When you enable autoboot, you are also prompted to enter a countdown value (10 seconds is the default). The ARC console waits for the duration of the countdown value before booting the system.

Install New Firmware

The Install new firmware command is located in the Supplementary menu. Use this command to install firmware upgrades. When selected, the floppy drive and CD-ROM (compact disc read only memory) are checked for the firmware update tool. If the proper media is not present, this command times out. Follow the instructions packaged with the firmware update.

Console Commands

Install Windows NT from CD-ROM

The Install Windows NT from CD-ROM command is located in the Supplementary menu. You must put the Microsoft Windows NT Server CD (compact disc) into the CD drive before selecting this command.

Switch to OpenVMS or OSF Console

The Switch to OpenVMS or OSF console command is located in the Setup menu. Use this command to select the operating system console to be launched at the next power cycle.

SRM Console

The SRM console supports the OpenVMS and DEC OSF/1 operating systems. The SRM console offers many different commands. For a complete list of SRM commands, type `help` at the SRM prompt (`>>>`). This section describes environment variables and the following commands:

- `boot`
- `set`
- `show`
- `examine`
- `deposit`
- `ISACFG`

SRM Console Conventions

Table A-1 lists SRM console conventions.

Table A-1. SRM Console Conventions

Item	Convention
Console prompt	<code>>>></code>
Continuation line prompt	<code>_></code>
Maximum command length	255 characters
Multiple contiguous spaces or tabs	Treated as a single space
Command abbreviations	Allowed, if not ambiguous
Command qualifiers or options	Prefix with a space and a dash "-"
Numbers	Hexadecimal, unless otherwise specified. (Note that registers such as R0-R31 are shown in decimal notation.)

Console Commands

SRM Console Special Characters

Table A-2 lists console special characters and their functions.

Table A-2. SRM Console Special Characters

Character/Key(s)	Function
Return	Terminates command line input.
← Backspace	Deletes the previously typed character.
[Ctrl]+[A]	Toggles insert/overstrike mode. (Overstrike is the default.)
[Ctrl]+[B], ↑, or ↓	Recalls previous commands. (The last 16 commands are stored.)
[Ctrl]+[C]	Terminates the foreground process.
[Ctrl]+[D] or ←	Moves the cursor left one position.
[Ctrl]+[E]	Moves the cursor to the end of the line.
[Ctrl]+[F] or →	Moves the cursor right one position.
[Ctrl]+[H]	Moves the cursor to the beginning of the line.
[Ctrl]+[O]	Suppresses/resumes (toggles) console output.
[Ctrl]+[Q]	XON, resumes flow of data to the console.
[Ctrl]+[S]	XOFF, stops the flow of data to the console.
[Ctrl]+[U]	Deletes the entire line.
[Ctrl]+[R]	Retypes the current command line.

Boot Command

The boot command performs the following functions:

- Initializes the processor
- Loads a program image from the specified boot device
- Transfers control to the loaded image

The syntax of the boot command is shown below:

```
boot [-file <filename>] [-flags <longword>[,<longword>]]
[-protocols <enet_protocol>] [-halt] [<boot_device>]
```

The boot command options are described in Table A-3.

Table A-3. SRM Boot Command Options

Command Option	Description
-file <filename>	Specifies the name of a file to load into the system. For booting from Ethernet, this name is limited to 15 characters. Use the set boot_file command to set the environment variable that specifies a default boot file.
-flags <longword>[,<longword>]	Specifies additional information for the operating system. For systems with OpenVMS, root number and boot flags are specified here. For DEC OSF/1 systems, the following values may be used: i – interactive boot s – boot to single user a – autoboot to multiuser Use the set boot_osflags command to set an environment variable that specifies a default boot flag value.
-protocols <enet_protocol>	Specifies the Ethernet protocol(s) used for a network boot. Values may be mop <i>or</i> bootp.
-halt	Forces the bootstrap operation to halt and invoke the console program after the image is loaded and the page tables and other data structures are set up.
<boot_device>	Specifies a device path or list of devices that the firmware attempts to boot. Use the set bootdef_dev command to set an environment variable that specifies a default boot device.

Console Commands

Boot Command Examples

Table A-4 shows boot command examples and their descriptions.

Table A-4. SRM Boot Command Examples

Command	Description
>>>boot	Boots the system from the default boot device.
>>>boot ewa0	Boots the system from Ethernet port ewa0.
>>>boot -file dec2.sys ewa0	Boots the file named dec2.sys from Ethernet port ewa0.
>>>boot -protocol bootp ewa0	Boots using TCP/IP BOOTP protocol from Ethernet port ewa0.
>>>boot -flags 0,1	Boots the system from the default boot device using flag settings 0,1.
>>>boot -halt dka0	Loads the image from disk dka0, but remains in console mode.

Set Command

The set command sets or modifies the value of an environment variable. Environment variables pass configuration information between the console and the operating system.

The syntax of the set command is shown below:

```
set <envar> <value> [-default] [-integer] [-string]
```

The set command options are described in Table A-5.

Table A-5. SRM Set Command Options

Command Option	Description
<envar>	The environment variable to be assigned a new value.
<value>	The value that is assigned to the environment variable. It can be either a numeric value or an ASCII string.
-default	Restores an environment variable to its default value.
-integer	Creates an environment variable as an integer.
-string	Creates an environment variable as a string.

Set Command Examples

Table A-6 shows set command examples and their descriptions.

Table A-6. SRM Set Command Examples

Command	Description
>>>set bootdef_dev ewa0	The default boot device is set to ewa0.
>>>set auto_action boot	The console attempts to boot following an error, halt, or power-up.
>>>set boot_osflags 0,1	The default boot flags are set to 0,1.
>>>set foobar 5	An environment variable called foobar is created and given a value of 5.
>>>set os_type NT	Sets up the system to start the ARC console after the next power cycle.

Console Commands

Show Command

The show command displays the current value of a specified environment variable. The show command also displays information about the system, according to the arguments entered.

The syntax of the show command is shown below:

```
show [{config, device, hwrpb, memory, pal, version,  
<envar>...}]
```

The show command options are described in Table A-7.

Table A-7. SRM Show Command Options

Command Option	Description
config	Displays the current memory configuration, PCI logical slots, and ISA logical slots (based on ISACFG utility input to the configuration database).
device [device name]	Displays the devices and controllers in the system. Specifying a device name returns information on that device only.
<envar>	Displays the value of the environment variable specified.
error	Displays error log information.
map	Displays the system virtual memory map.
memory	Displays the memory module configuration.
pal	Displays the version of OpenVMS and OSF PALcode.
version	Displays the version of the console firmware.

Show Command Examples

Table A-8 lists show command examples and their descriptions.

Table A-8. SRM Show Command Examples

Command	Description
<pre>>>>show device dka0.0.0.6.0 DKA0 RZ26L 441A dka400.4.0.6.0 DKA400 RRD43 3213 dva0.0.0.0.1 DVA0 ewa0.0.0.12.0 EWA0 08-00-2B-E2-1C-25 pka0.7.0.6.0 PKA0 SCSI Bus ID 7</pre>	<p>Lists device information such as system designation, drive model, or Ethernet address.</p>
<pre>>>>show memory 48 Meg of System Memory Bank 0=16 Mbytes (8 MB per Simm) Starting at 0x2000000 Bank 1=32 Mbytes (16 MB per Simm) Starting at 0x0 Bank 2=No Memory Detected</pre>	<p>Lists system RAM (random access memory), bank sizes, and starting addresses.</p>
<pre>>>>show * (See the next section.)</pre>	<p>Lists all variables and their settings.</p>
<pre>>>>show boot* (See the next section.)</pre>	<p>Lists all variables beginning with boot.</p>

Console Commands

Examine Command

The examine command displays the contents of an address you specify. The address can be a memory location, register, device, or file.

The syntax of the examine command is shown below:

```
examine [-{b,w,l,q,o,h,d}] [-{physical, virtual, gpr, fpr, ipr}] [-n <count>] [-s <step>] [<device>:]<address>
```

The examine command options are described in Table A-9.

Table A-9. SRM Examine Command Options

Command Option	Description
-b	Byte of data.
-w	Word of data.
-l	Longword of data.
-q	Quadword of data.
-o	Octaword of data.
-h	Hexaword of data.
-d	Displays data as a decoded macro instruction.
-physical	References physical address space.
-virtual	References virtual address space.
-gpr	References general purpose register address space.
-fpr	References floating point register (FPR) address space.
-ipr	References internal processor register (IPR) address space.
-n <count>	Specifies the number of consecutive locations to examine.
-s <step>	Specifies the address increment as a hexadecimal value. This option allows you to override the increment that is normally derived from the data size.
<device>:]	Selects the device to access.
<address>	Specifies the address of the first location to examine within the current device.

Examine Command Examples

Table A-10 shows examine command examples and their descriptions.

Table A-10. SRM Examine Command Examples

Command	Description
>>>e r0 gpr: 0 (R0) 0000000000000002	Examines R0 using a symbolic address.
>>>e -g 0 gpr: 0 (R0) 0000000000000002	Examines R0 using address space.
>>>e gpr:0 gpr: 0 (R0) 0000000000000002	Examines R0 using device name.
>>>e pc PC psr: 0(PC) FFFFFFFF80072954	Examines the system.
>>>examine -n 5 r7 gpr: 38 (R7) 0000000000000000 gpr: 40 (R8) 0000000000000000 gpr: 48 (R9) 0000000000000000 gpr: 50 (R10) 000000007FFBF800 gpr: 58 (R11) 000000007FF781A2 gpr: 60 (R12) 0000000000000000	Examines R7 and the next 5 registers.
>>>examine ipr:11 ipr: 11 (KSP) FFFFFFFF8228DFD0	Examines internal processor register 11.

Console Commands

Deposit Command

The deposit command writes data to an address that you specify. The address can be a memory location, register, device, or file.

The syntax of the deposit command is shown below:

```
deposit [-{b,w,l,q,o,h}] [-{physical,virtual,gpr,fpr,ipr}] [-n  
<count>] [-s <step>] [<device>:]<address> <data>
```

The deposit command options are described in Table A-11.

Table A-11. SRM Deposit Command Options

Command Option	Description
-b	Byte of data.
-w	Word of data.
-l	Longword of data.
-q	Quadword of data.
-o	Octaword of data.
-h	Hexaword of data.
-physical	References physical address space.
-virtual	References virtual address space.
-gpr	References general purpose register address space.
-fpr	References floating point register (FPR) address space.
-ipr	References internal processor register (IPR) address space.
-n <count>	Specifies the number of consecutive locations to examine.
-s <step>	Specifies the address increment as a hexadecimal value. This option allows you to override the increment that is normally derived from the data size.
[<device>:]	Selects the device to access. The following devices are supported: <ul style="list-style-type: none">• pmem: physical memory.• vmem: virtual memory. All access and protection checking occurs.

Table A-11. SRM Deposit Command Options (continued)

Command Option	Description
<address>	<p>An address that specifies the offset within a device into which data is deposited. The address can also be any legal symbolic address. Valid symbolic addresses are:</p> <ul style="list-style-type: none"> • <i>gpr-name</i>. Symbol representing General Purpose Register. • <i>ipr-name</i>. Symbol representing Internal Processor Register. • <i>PC</i>. Program Counter. • <i>+</i>. The location immediately following the last location referenced by an examine or deposit. • <i>-</i>. The location immediately preceding the last location referenced by an examine or deposit. • <i>*</i>. The location last referenced by an examine or deposit. • <i>@</i>. The location addressed by the last location referenced by an examine or deposit.
<data>	The data to be deposited.

Deposit Command Examples

Table A-12 shows deposit command examples and their descriptions.

Table A-12. SRM Deposit Command Examples

Command	Description
>>>d -n 1FF pmem:0 0	Clears the first 512 bytes of physical memory.
>>>d -l -n 3 pmem:1234 5	Deposits 5 into four longwords starting at physical memory address 1234.
>>>d -n 8 R0 FFFFFFFF	Loads GPRs R0 through R8 with -1.
>>>d -l -n 10 -s 200 pmem:0 8	Deposits 8 in the first longword of the first 17 pages in physical memory.

Console Commands

Environment Variables

Table A-13 shows selected environment variables and their descriptions (for a complete list, type show * at the SRM prompt).

Table A-13. SRM Environment Variables

Variable	Description
<i>auto_action</i>	Sets/shows the console action following an error, halt, or power-up. The action can be <code>halt</code> , <code>boot</code> , or <code>restart</code> . <code>halt</code> is the default.
<i>boot_file</i>	Sets/shows the file name to be used when a bootstrap requires a file name. The default setting is null.
<i>boot_osflags</i>	Sets/shows additional parameters to be passed to system software. When using OpenVMS software, these parameters are the system root number and boot flags. The default setting is 0,0.
<i>bootdef_dev</i>	Sets/shows the default device or device list from which the system attempts to boot. If the system software is preloaded, the variable is preset to point to the device containing the preloaded software. Otherwise, the default value is null.
<i>console</i>	Sets the console output to either <code>serial port</code> or the graphics controller.
<i>control_scsi_term</i>	Internal: The SCSI is internally terminated at both ends. Do not add any external devices when the variable is set to this value. This is the default setting. External: The SCSI bus is internally terminated at one end. The other end of the SCSI bus must be terminated externally at the last external device in the SCSI chain.
<i>os_type</i>	Sets/shows the specified operating system (NT, OpenVMS, or OSF) that NVRAM boots.
<i>pci_parity</i>	This variable controls PCI parity checking at the PCI bridge chip. Parity checking is performed if on, disabled if off, and dependent on the SCSI controller revision if sniff.

ISA Configuration Utility

ISA (industry-standard architecture) devices are not capable of being probed for configuration information by the DEC OSF/1 or OpenVMS operating systems. Therefore, you must enter ISA option information manually using the ISA configuration utility (ISACFG). Run this utility before installing a new ISA option module on a Digital AlphaServer 400 Series system running either the DEC OSF/1 or OpenVMS operating systems.

The Digital AlphaServer 400 Series system has five IRQ levels available for ISA and PCI expansion (5, 9, 10, 14, and 15). Prior to adding an ISA device, you must use ISACFG to assign an IRQ to the device. Make sure to leave enough IRQs unassigned to meet the needs of your PCI devices. (The embedded PCI-based SCSI controller is assigned automatically to IRQ11.) For example, if your system has two PCI slots occupied, you can add up to three ISA devices. You can add a fourth ISA device if ISACFG is used to disable another ISA device, such as the COM2 port. Disabling the COM2 port makes IRQ3 available for the new ISA device.

Command Format

The syntax of the ISACFG command is shown below:

```
isacfg [-slot <slot#>] [-dev <device#>]
[-all|-rm|-mk|-mod] [-<field> <value>] . . .
```

The ISACFG command options are described in Table A-14.

Table A-14. SRM ISACFG Command Options

Command Option	Description
-all	Shows the entire configuration table. Overrides all other commands.
-dev <dev#>	Optional; defaults to 0 if not entered. On a multifunction or multiport adapter, this specifies the device on the adapter.
-dmachan{0-3} <#>	Allows you to specify up to four DMA (direct memory access) channels for the device.
-dmamode{0-3} <#>	Allows you to specify the DMA type for -dmachan{0-3}. DMA modes are: 1 - Block 2 - Demand 4 - Single 8 - Cascade

Table A-14. SRM ISACFG Command Options (continued)

Command Option	Description
-enadev <#>	Allows you to specify whether an entry is enabled or disabled. Disabled devices are not used in resource allocation calculations. The possible values are: 0 - No (disabled) 1 - Yes (enabled)
-etyp <#>	Defines an entry type for this entry. The # sign can be: 0 - Causes the entry to be deleted 1 - Single option 2 - Embedded multiport device 3 - Multiport option device
-handle <string>	Binds a name to the driver (up to 15 characters).
-init	Initializes the configuration table to the default settings.
-iobase{0-5} <#>	Specifies up to six I/O base registers (in hexadecimal) for a particular device entry.
-irq{0-3} <#>	Allows you to assign up to four IRQ (interrupt request) channels to the device (use decimal IRQ levels).
-membase{0-2} <#>	Specifies up to three R/W ISA memory regions.
-memlen{0-2} <#>	Specifies the length corresponding to membase{0-2}.
-mk	Adds an entry into the table.
-mod	Modifies an entry in the table.
-rm	Deletes an entry from the table.
-rombase <#>	Specifies an address for ISA BIOS ext. ROM.
-romlen <#>	Specifies the length of ROM.
-slot <slot#>	Allows you to enter a unique slot number for each ISA adapter. You can assign the numbers in any order. The slot number does not relate to a physical ISA adapter position in the motherboard. Slot 0 is reserved for the local multiport adapter.
-totdev <#>	Placeholder for you to keep track of the total number of devices, specified by the # sign, at this slot. Modify this for your own use.

Adding ISA Options to OpenVMS and DEC OSF/1 Systems

When you add a supported ISA option to an AlphaServer 400 Series system running the OpenVMS or DEC OSF/1 operating system, perform the procedure in Table A-15.

Table A-15. Adding Options to OpenVMS or DEC OSF/1 Systems

Step	Action	Result or Next Step
1	Perform operating system configuration tasks, if any. Refer to your operating system installation guide and release notes.	The operating system is prepared for the ISA option.
2	Shut down the system.	The system is at the console prompt (>>>).
3	>>> <i>isacfg options</i>	Adds the new ISA option to the SRM console configuration table using the appropriate command options.
4	>>> <i>init</i>	Typing <i>init</i> allows the changes to be used.
5	Configure the ISA option.	Use the manual that came with your ISA option to set the proper configuration.
6	Turn off the system and install the ISA option.	Refer to Chapter 3, Expanding Your System, in this information.
7	Turn on the system and boot.	The operating system boots and sees the new ISA option.

Console Commands

ISACFG Command Examples

This section shows examples of ISACFG commands you use to enter the DE205, sound card, and FAX/MODEM options into the configuration database. Examples to display, modify, and remove table entries are included as well. In some cases, scripts are available to issue the proper ISACFG command. Include an "add_" prefix before script commands. To run long commands onto the next line, type a backslash (\) at the end of the line.

☞ You can record system configuration data on the equipment logs in Appendix G.

Adding the DE205 option:

```
>>>add_de205
-or-
>>>isacfg -slot 1 -dev 0 -mk -handle DE200-LE \
_> -irq0 5 -iobase0 300 -etyp 1 -enadev 1
```

Adding the sound card option:

```
>>>add_sound
-or-
>>>isacfg -slot 2 -etyp 1 -mk -iobase0 530 -iobase1 388 \
_> -irq0 9 -dmachan0 0 -dmachan1 1 -handle PCXBJ -enadev 1
```

Adding the FAX/MODEM option:

```
>>>add_fax
-or-
the following two commands:
>>>isacfg -mod -slot 0 -dev 3 -enadev 0
>>>isacfg -slot 4 -dev 0 -mk -handle COM4 -irq0 3 \
_> -iobase0 2e8 -etyp 1 -enadev1
```

Displaying the configuration database:

```
>>>isacfg -all
```

Modifying the IRQ0 entry of an option:

```
>>>isacfg -mod -slot 1 -irq0 14
```

Removing an entry:

```
>>>isacfg -rm -slot 1 -dev 0
```

B

System Care

Introduction

This appendix describes how to:

- Clean your system, including the outside enclosure, monitor screen, mouse, and keyboard
- Move your system

WARNING

Make sure you turn off the system and disconnect any external devices before cleaning any part of your system. When using a moistened cloth for cleaning, do not allow any excess fluid to leak into the system, keyboard, or monitor. Wait until the system is completely dry before applying power.

Cleaning Your System Unit

Clean the outside of the system periodically with a soft cloth lightly moistened with a mild detergent solution. Do not use solvents or abrasive cleaners.

Cleaning Your Monitor

If the monitor screen gets dirty, clean it with a sponge or chamois cloth lightly dampened with a mild detergent solution. Do not use solvents or abrasive cleaners.

WARNING

If you use a prepackaged screen cleaner, make sure that it is *nonflammable*. Never spray the cleaner directly on the screen. Instead, apply the cleaner to a clean cloth, and then wipe the screen.

Cleaning Your Mouse

If your mouse does not move smoothly or if the pointer jumps across the screen when you are using the mouse, the ball inside the mouse might need cleaning. To clean the ball, perform the following steps, as Figure B-1 shows:

1. Turn the mouse over and remove the plate on the bottom.
2. Remove the locking ring and the rubber ball ①.
3. Clean the ball and rollers② with a cotton swab that has been lightly dampened with a mild detergent.
4. Replace the ball and plate ③.

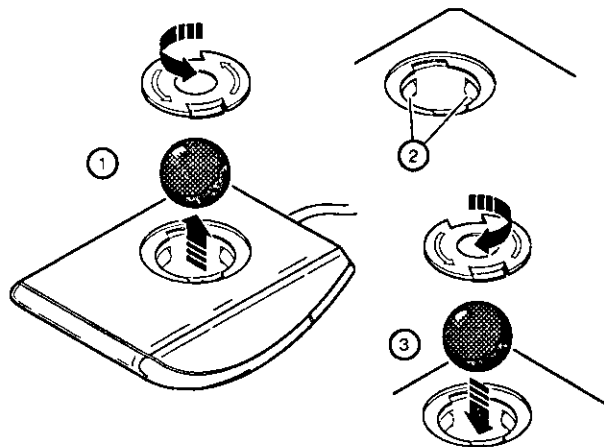

Figure B-1. Cleaning the Mouse

Cleaning Your Keyboard

From time to time, your keyboard keys might get dirty with use. Clean them with a fresh cloth that has been lightly dampened with a mild detergent solution.

Moving Your System

Perform the following steps before shipping or moving the system:

1. Back up all files stored on the hard disk drive.
2. Turn off the external peripherals, the system, and the monitor.
3. Disconnect the power cord from the wall outlet and from the back of the system unit.
4. Disconnect the monitor, keyboard, mouse, and any other cables from the back of the system unit.
5. Package the system as described in the next section, Packing Your System.

Packing Your System

If you are moving the system a short distance (for example, from one room to another in the same building), you do not have to pack it. If you are shipping the system or moving it by vehicle, pack it to avoid damage.

Pack the system in the original packing material and containers. If you did not save the boxes and packing material, use a sturdy carton and cushion the computer well to avoid damage.

Installing Your System at a New Location

After moving the system to a new location, follow the installation instructions on the installation information to unpack and install it.

Technical Specifications

Introduction

This appendix describes the following technical characteristics of the Digital AlphaServer 400 Series system:

- System specifications
- External system connectors
- Expansion slot current limitations
- System current requirements
- Motherboard jumpers

System Specifications

Tables C-1 through C-4 list the Digital AlphaServer 400 Series system processor features, dimensions, environmental, and acoustics specifications.

Table C-1. System Specifications

Attributes	Specification
PCI clock	33 MHz
Data I/O	32-bit PCI
Motherboard RAM	Expandable up to 192 MB
Total SCSI bus length	3 meters (9.8 feet) for fast SCSI operation 4 meters (13.1 feet) for slow SCSI operation

Technical Specifications

Table C-2. System Dimensions

Dimension	Specification
Width	177.8 mm (7.0 in)
Length	431.8 mm (17.0 in)
Height	431.8 mm (17.0 in)
Weight	12+ kg (28+ lb)

Table C-3. System Environmental Specifications

Attributes	Specification
Operating temperature	10°C to 40°C (50°F to 104°F)
Storage temperature	-20°C to 65°C (-4°F to 149°F)
Operating humidity (noncondensing)	20% to 80% relative humidity, maximum wet bulb 40°C (104°F)
Storage humidity (noncondensing)	10% to 90% relative humidity, maximum wet bulb 65°C (149°F)
Altitude Operating Nonoperating	2,438 m (8,000 ft) maximum 4,876 m (16,000 ft) maximum
Shipping vibration	IAW Federal Standard 101, method 5019
Nonoperating shock	30 G, 25 ms halfsine

Table C-4. Acoustics-Declared Values per ISO 9296 and ISO 7779

Product	Sound Power Level L _{WA} d, B		Sound Pressure Level L _{pAm} , dBA (operator position)	
	Idle	Operate	Idle	Operate
PB500-AA	5.1	5.2	33	34

NOTE

1B=10 dBA.

External System Connectors

This section lists the pin assignments for your system's external connectors:

- Bidirectional connector, 25-pin D-submini female
- Serial connectors, 9-pin D-submini male
- Keyboard and mouse connectors, 6-pin mini-DIN
- SCSI port, high-density, shielded

Bidirectional Parallel Port Connector

The bidirectional connector provides an interface to a printer or other parallel devices.

Table C-5 lists pin assignments. An asterisk (*) after a signal name indicates an active low signal.

Table C-5. Bidirectional Parallel Port Pinouts

DB25 Pin	Signal	Function
1	STB-R*	Strobe
2	PRTD0	Printer data bit 0
3	PRTD1	Printer data bit 1
4	PRTD2	Printer data bit 2
5	PRTD3	Printer data bit 3
6	PRTD4	Printer data bit 4
7	PRTD5	Printer data bit 5
8	PRTD6	Printer data bit 6
9	PRTD7	Printer data bit 7
10	ACK*	Acknowledge
11	BUSY	Busy
12	PE	Paper end
13	SLCT	Select
14	AUTOFDXT*	Autofeed
15	ERR*	Error
16	INIT*	Initialize printer
17	SLCTIN*	Select input
18 to 25	GND	Ground

Technical Specifications

Serial Port Connectors

The serial port connectors consist of two 9-pin D-submini connectors. Table C-6 lists their pin assignments.

The baud rates supported by the system's serial ports are 300; 1200; 2400; 4800; 9600; 19,200; and 38,400.

Table C-6. 9-Pin Serial Port Pinouts

DB9 Pin	Signal	Function
1	DCD	Data carrier detect
2	RXD	Receive data
3	TXD	Transmit data
4	DTR	Data terminal ready
5	GND	Ground
6	DSR	Data set ready
7	RTS	Request to send
8	CTS	Clear to send
9	RI	Ring indicator

Keyboard and Mouse Connectors

The keyboard and mouse connectors consist of two 6-pin mini-DIN connectors. Table C-7 lists their pin assignments.

Table C-7. Keyboard and Mouse Connector Pinouts

Pin	Signal
1	Data
2	Reserved
3	Ground
4	+5 Volts dc (fused)
5	Clock
6	Reserved

SCSI Port Connector

The external SCSI connector is a 50-pin high-density connector. Table C-8 lists the pin assignments.

Table C-8. SCSI Port Pinouts

Pin	Signal	Pin	Signal
1	gnd	26	-DB (0)
2	gnd	27	-DB (1)
3	gnd	28	-DB (2)
4	gnd	29	-DB (3)
5	gnd	30	-DB (4)
6	gnd	31	-DB (5)
7	gnd	32	-DB (6)
8	gnd	33	-DB (7)
9	gnd	34	-DB (P)
10	gnd	35	gnd
11	gnd	36	gnd
12	reserved	37	reserved
13	open	38	TERMPWR
14	reserved	39	reserved
15	gnd	40	gnd
16	gnd	41	-ATN
17	gnd	42	gnd
18	gnd	43	-BSY
19	gnd	44	-ACK
20	gnd	45	-RST
21	gnd	46	-MSG
22	gnd	47	-SEL
23	gnd	48	-CD
24	gnd	49	-REQ
25	gnd	50	-I/O

Technical Specifications

Expansion Slots

The motherboard contains two PCI, three ISA, and one combination PCI/ISA expansion slots. The maximum available +5 Volts DC current allowable to any expansion slot depends on the following parameters:

- Power supply capacity
- +5 Volts DC requirements of the motherboard
- +5 Volts DC requirements of the peripherals
- Power demands of all other slots in use

Power Supply and Input Power Requirements

The 300-watt power supply provides five dc voltages: +12 Volts, -12 Volts, +5 Volts, -5 Volts, and +3.3 Volts DC. These voltages are used by the various components within the system. Table C-9 lists the input power requirements.

Table C-9. System Input Power Requirements

Rated Voltage Range	Maximum Range	Rated Input Current ¹	Operating Frequency Range
100 Volts AC – 120 Volts AC	88 Volts AC– 132 Volts AC	8 A	47 Hz– 63 Hz
220 Volts AC – 240 Volts AC	176 Volts AC – 264 Volts AC	4 A	47 Hz– 63 Hz

¹ Includes outlet current.

Jumpers

Jumper pins allow you to set specific system parameters. Set them by changing the pin location of jumper blocks. (A *jumper block* is a small plastic-encased conductor [shorting plug] that slips over the pins.) To change a jumper setting, remove the jumper from its current location with your fingers or small needle-nosed pliers. Place the jumper over the two pins designated for the desired setting. Press the jumper evenly onto the pins. Be careful not to bend the pins.

Motherboard Jumpers

Figure C-1 shows the locations of the motherboard jumper pins. Table C-10 lists the motherboard jumpers and factory-default settings. Note that the square pin of each jumper block is pin 1.

CAUTION

Do not touch any electronic component unless you are safely grounded. Wear a grounded wrist strap or touch an exposed metal part of the system unit chassis. A static discharge from your fingers can permanently damage electronic components.

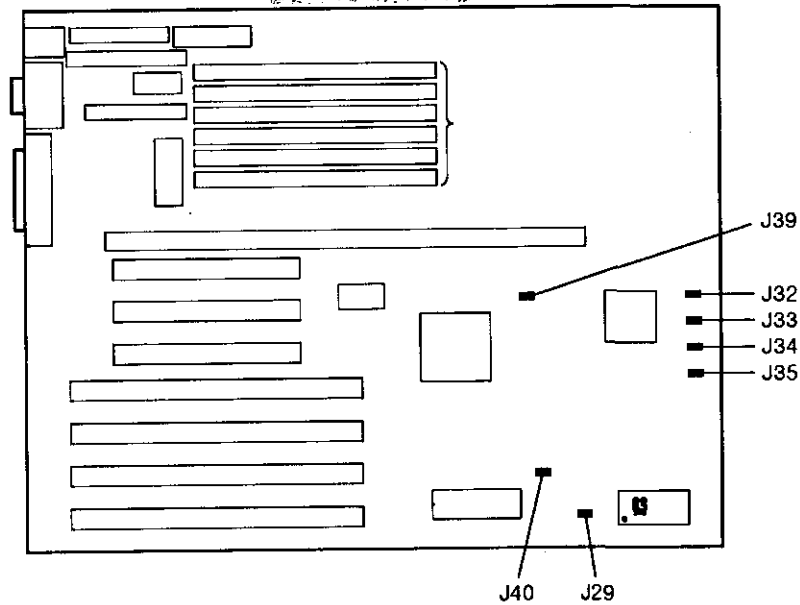

Figure C-1. Motherboard Jumper Locations

Technical Specifications

Table C-10. Motherboard Jumper Settings

Jumper	Setting	Function	Description
J29	1 to 2	CMOS clear	CMOS clear
	2 only (D)	Normal	
J32	1 to 2	Password clear	Password clear (not used on the AlphaServer 400 system)
	2 only (D)	Normal	
J33	1 to 2	Color	Display type (not used on the AlphaServer 400 system)
	2 only (D)	Mono	
J34	1 to 2	Recovery mode	Recovery mode (not used on the AlphaServer 400 system)
	2 only (D)	Normal	
J35	1 to 2 (D)	Enabled	BIOS upgrade (not used on the AlphaServer 400 system)
	2 only	Disabled	
J39	1 to 2 (D)	Alpha architecture	CPU selection
	2 only	Unsupported	
J40	1 to 2 (D)	Disabled	Reprogram boot block (not used on the AlphaServer 400 system)
	2 to 3	Enabled	

(D) = Default position.

CPU Module Jumpers

Figure C-2 shows the locations of the CPU module jumper pins. Table C-11 lists the CPU module jumpers and factory-default settings.

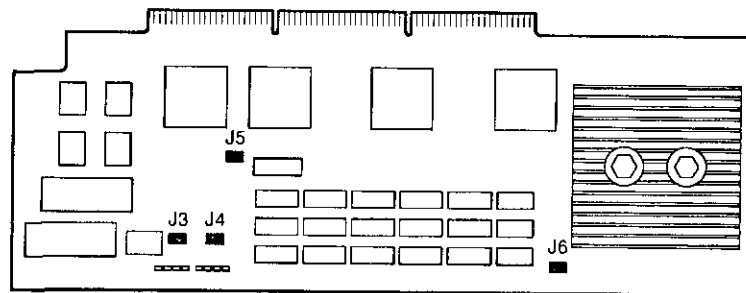

Figure C-2. CPU Module Jumper Locations

Table C-11. CPU Module Jumper Settings

Jumper	Setting	Function	Description
J3	1 to 2 2 to 3 (D)	SROM mini-console Pass control to DROM	J3 is used to control whether the SROM code goes to the mini console (for manufacturing) or loads the DROM code.
J4	1 to 2 (D) 2 to 3	Write Enabled Write Disabled	J4 controls the flashROM write enable. The flashROMs are written when firmware is updated.
J5	1 to 2 2 to 3 (D)	DROM loads floppy DROM loads flashROM	J5 is used to control whether DROM code loads the floppy disk or loads the console firmware from the flashROM.
J6	1 to 2 (D) 2 to 3	Reset Unsupported	J6 controls the function of the front panel pushbutton.

(D) = Default position

D

Device Mapping

Introduction

This appendix lists system device mapping information, including:

- I/O address map
- Interrupt assignments
- DMA channel assignments

I/O Address Map

Table D-1 presents information on the I/O address map.

Table D-1. I/O Address Map

ISA I/O Addresses	Devices
0000-02F7	Reserved
02F8-02FF	Serial port 2
03BC-03BE	Parallel port
03BF-03EF	Reserved
03F0-03F7	Floppy disk
03F8-03FF	Serial port 1
0400-07FF	Reserved

Device Mapping

Interrupt Map

The IRQ assignments for the Digital AlphaServer 400 Series are shown in Table D-2. This information is useful when adding or reconfiguring options on your system. Avoid conflicts when assigning IRQs by associating one IRQ to one source. PCI interrupt levels are set either by the operating system (as in the Windows NT operating system) or by the SRM console (as in the OpenVMS and DEC OSF/1 operating systems).

Table D-2. System Interrupt Assignments

IRQ#	Source
0	Timer/counter
1	Keyboard
2	Internal cascade of 8259
3	Serial port 2 or ISA slot
4	Serial port 1 or ISA slot
5	Parallel port, PCI interrupt, or ISA slot
6	Floppy controller or ISA slot
7	Parallel port or ISA slot
8	Reserved
9	PCI interrupt or ISA slot
10	PCI interrupt or ISA slot
11	SCSI controller or ISA slot
12	Mouse or ISA slot
13	Reserved
14	ISA slot
15	PCI interrupt or ISA slot

DMA Channel Assignments

The DMA channel assignments for ISA options are shown in Table D-3. This information is useful when adding ISA options to your system. Avoid DMA channel conflicts by not assigning multiple devices to the same channel.

Table D-3. DMA Channel Assignments

Channel	Device
0	Available to ISA slots.
1	Available to ISA slots.
2	Floppy disk controller.
3	Parallel port, ISA slots.
4	Unavailable. (Channels 0-3 are cascaded to this channel.)
5	Available to ISA slots.
6	Available to ISA slots if IDE is not present.
7	Available to ISA slots.

Updating System Firmware

Introduction

This appendix explains how to use the firmware update utility to install firmware upgrades.

NOTE

The user is responsible for performing system firmware upgrades. Consult your upgrade documentation for more information.

System Firmware

The Digital AlphaServer 400 Series system contains four flashROMs, two with ARC (advanced RISC computing) console firmware (for the Windows NT operating system) and two with SRM (system reference manual) console firmware (for the DEC OSF/1 and OpenVMS operating systems).

Update Utility

Use the update utility to update your ARC and SRM firmware. The update utility contains three images: the update utility itself, the SRM image, and the ARC image.

Flash Enable Jumper

The flashROM write enable jumper (J4) is located on the CPU module and should be set to enable updates. If you have any problems updating firmware, check the jumper to ensure that it is set properly.

Upgrading System Firmware

Using the Flash Update Utility From the SRM Console

To update the firmware from the SRM console, do the following:

1. Insert the Firmware Update CD-ROM (compact disc read only memory) into the CD drive.
2. Type the show device command to determine the device ID of the CD drive.

```
>>>show device
```

```
dka0.0.0.6.0      DKA0      RZ26L          440C
dka400.4.0.6.0    DKA400    TOSHIBA CD-ROM 0064
dva0.0.0.0.1      DVA0
ena0.0.0.1.1      ENA0      08-00-2B-38-67-6B
pka0.7.0.6.0      PKA0      SCSI Bus ID 7
```

3. Boot the Firmware Update Utility CD-ROM using the device ID display in step 2..

You should see a display similar to the following, while the update utility is loading and executing:

```
>>>b -f1 0,a0 dka400
Bootfile: [alpha200]as200_v2_8.exe
bootstrap code read in
base = 11e000, image_start = 0, image_bytes = ea800
initializing HWRPB at 2000
initializing page table at 110000
initializing machine state
setting affinity to the primary CPU
jumping to bootstrap code
ff.fe.fd.fc.fb.fa.f9.f8.f7.f6.f5.
ef.df.ee.ed.ec.f4.eb.....ea.e9.e8.e7.e5
X3.7-10895, built on Sep 13 1994 at 11:29:42
>>>Execute Update Sequence
Update Script Complete
/boot pmem:180000 -flags 0,0)
bootstrap code read in
base = 180000, image_start = 0, image_bytes = 800000
initializing HWRPB at 2000
initializing page table at 710000
initializing machine state
setting affinity to the primary CPU
jumping to bootstrap code
```

Upgrading System Firmware

```
apu-version 959328854 *** Firmware Update Utility v2.9 ***  
*** System Type: Alpha Workstation 200/400 ***  
Update  
Verify  
List  
Show  
Dump  
Verbose  
Nverbose  
Debug  
Ndebug  
?
```

Apu->

4. To update the firmware, type `update`. The following information will be displayed as the firmware is being updated. The actual information may change between versions.

```
Apu-> update  
APU-I *** ROM 0,1 Contents will be destroyed ***  
APU-I Are you ready to Program Device? (y/n)y  
APU-I Programming device  
APU-I Programming device completed  
APU-I Programming device  
APU-I Programming device completed  
Apu->
```

5. Use the `verify SRM` command to verify the integrity of the SRM firmware. First enable verbose mode by typing `verbose`; then type `verify`.

Apu-> `verbose`

Apu-> `verify`

6. To exit the update utility, cycle the power. Leave the power off for at least 20 seconds.

NOTE

Commands such as `Dump`, `List`, `Show`, and `Verify` must have verbose mode enabled for their output to be displayed. Type the `Verbose` command at the `Apu->` prompt to enable verbose mode.

Upgrading System Firmware

Using the Flash Update Utility From the ARC Console

To update the firmware from the ARC console, do the following:

1. Insert the Firmware Update CD-ROM (compact disc read only memory) into the CD drive.
2. From the ARC Boot Menu, select `Supplementary menu . . .`
3. Select `Install new firmware`, and complete the update procedure by going to step 4 in the previous section, `Using the Flash Update Utility From the SRM Console`.

Starting an Operating System Installation

Introduction

This information provides what you need to begin an operating system installation. Once you have started an installation, follow the on-screen instructions and refer to the appropriate operating system documentation.

Using the table below, first locate the operating system you want to install and refer to the appropriate table number.

If you want to:	Go to Table:
Install Windows NT Server on a properly partitioned and formatted disk	F-1
Set up partitions for a Windows NT Server installation	F-2
Install DEC OSF/1	F-3
Install OpenVMS	F-4

CAUTION

If you boot from a DEC OSF/1 or OpenVMS disk and also occasionally boot Microsoft Windows NT Server from another disk, use caution when you run the Windows NT Disk Administrator. When the Disk Administrator detects additional disks, it updates the system configuration. The Disk Administrator prompts you for permission to write a signature to the additional disks. Writing the signature to a DEC OSF/1 or OpenVMS disk *destroys* the boot block on that disk and makes the operating system on that disk no longer bootable. Select **NO** when you are asked if you want to write a signature to your DEC OSF/1 or OpenVMS disks.

Starting an Operating System Installation

Starting a Windows NT Server Installation

Digital partitions and formats disk 0 on the first SCSI controller in non-RAID Windows NT Server systems. The partitions are set up as follows:

- Partition 1 (typically, the "C" drive) is the size of the disk less 6 MB and formatted FAT. Normally, you select "convert to NTFS" during the Windows NT installation.
- Partition 2 (typically, the "D" drive) is 6 MB, formatted FAT, and identified as the system partition.

Refer to Table F-1 for the steps to start installing Windows NT Server on a properly partitioned and formatted disk.

Table F-1. Starting a Windows NT Server Installation

Step	Action	Result
1	Insert the Microsoft Windows NT Server CD-ROM into the CD drive.	CD-ROM drive is ready.
2	From the ARC console boot menu, select Supplementary menu...	Supplementary menu appears.
3	Select Install Windows NT from CD-ROM.	Windows NT setup procedure starts. Follow the on-screen instructions. For more information, refer to the <i>Microsoft Windows NT Server System Guide</i> .

Starting an Operating System Installation

If you are installing the operating system on a disk that has not been partitioned and formatted, follow the procedure in Table F-2.

Table F-2. Setting Up Partitions for a Windows NT Server Installation

Step	Action	Result
1	If the ARC (advanced RISC computing) console is running, go to step 2. If the SRM (system reference manual) console is running, at the >>> prompt, type: >>>set os_type nt Then cycle the system's power. (Leave the power off for 20 seconds.)	Cycling power after specifying an os_type of <i>nt</i> results in the system restarting with the ARC console running. (You will know that the ARC console is starting when the screen turns blue.)
2	Insert the Microsoft Windows NT Server CD-ROM into the CD drive.	CD-ROM drive is ready.
3	From the ARC console, select Run a Program.	You are prompted for the program name. ARCINST, the ARC installation program, provides a means to partition and format the disk for NT prior to installing Windows NT.
4	At the prompt, type: cd:\alpha\arcinst	If you see receive a "Pathname is not defined" error, go to the ARC console Setup menu and select Set the environment variables. Select CD-ROM, then enter the SCSI bus number and ID of the CD-ROM drive. Next, select Set the default configuration and follow the steps. Save the changes and repeat step 4.
5	Choose Configure Partitions	Partition menu displays choices that allow you to create, delete, or make an existing partition into a system partition.
6	Choose Create Partition	A list of available target devices appears. Scsi bus 0,Identifier 0,Disk 0 (scsi(0)disk(0)rdisk(0)) Identifier is the ID of the SCSI device, drive 0 in this case.

Starting an Operating System Installation

**Table F-2. Setting Up Partitions for a Windows NT Server Installation
(continued)**

Step	Action	Result
7	Select the desired target device.	A prompt for partition size appears. The system partition should be 6 MB.
8	Enter the desired partition size of your "C" drive minus 6 MB.	Partition successfully created.
9	Press any key to continue.	Do you want to make this the system partition (y/n)?
10	Enter <code>n</code> and press return.	Partition formatted successfully.
11	Press any key to continue.	Configure Partitions menu reappears.
12	Choose Create Partition	A list of available target devices appears.
13	Select the desired target device.	A prompt for partition size appears.
14	Enter 6 MB as the desired partition size of your "D" drive.	Partition successfully created.
15	Press any key to continue.	Do you want to make this the system partition (y/n)?
16	Enter <code>y</code> and press return.	Partition formatted successfully.
17	Press any key to continue.	Configure Partitions menu reappears.
18	Select Exit.	ARCINST menu appears.
19	Select Exit.	ARC Boot menu appears.

Starting a DEC OSF/1 Installation

To start a DEC OSF/1 installation, follow the steps in Table F-3.

Table F-3. Starting a DEC OSF/1 Installation

Step	Action	Result
1	If the SRM console is running, go to step 3. If the ARC console is running, from the Boot menu select the Supplementary menu..., then select Set up the system..., then select Switch to OpenVMS or OSF console. Select Switch to OSF.	Selecting Switch to OSF will cause the system to run the SRM console after the next power cycle.
2	Cycle the system's power. (Leave the system off for 20 seconds.)	Cycling power after selecting the OpenVMS or OSF/1 console results in the system's restarting with the SRM console running.
3	At the SRM prompt, type: >>>set boot_osflags ""	Clear the <i>boot_osflags</i> variable.
4	At the SRM prompt, type: >>> set auto_action halt	Halts the system at the console prompt each time the system is turned on, crashes, or when the reset button is pushed.
5	Insert the <i>DEC OSF/1 for AXP™ Systems</i> CD-ROM into the CD drive.	CD-ROM drive is ready.
6	At the SRM prompt, type: >>>show dev	List of devices appears: dka0.0.0.6.0 DKA0 R226L 441A dka400.4.0.6.0 DKA400 RRD43 3213 dva0.0.0.0.1 DVA0
7	From the SRM console, boot the DEC OSF/1 CD-ROM. >>>boot dka400	Installation information is displayed and you are prompted to select an option. For more information, refer to the <i>DEC OSF/1 Installation Guide</i> .

Starting an OpenVMS Installation

To start an OpenVMS installation, follow the steps in Table F-4.

Table F-4. Starting an OpenVMS Installation

Step	Action	Result
1	If the SRM console is running, go to step 3. If the ARC console is running, from the Boot menu select the Supplementary menu..., then select Set up the system.... From the Setup menu, select Switch to OpenVMS or OSF console. Select Switch to OpenVMS.	Selecting Switch to OpenVMS causes the system to run the SRM console after the next power cycle.
2	Cycle the system's power. (Leave the system off for 20 seconds.)	Cycling power after selecting the OpenVMS or OSF/1 console results in the system's restarting with the SRM console running.
3	Insert the OpenVMS CD-ROM into the CD drive.	CD-ROM drawer closes.
4	At the SRM prompt, type: >>>show dev	List of devices appears: dka0.0.0.6.0 DKA0 RZ26L 441A dka400.4.0.6.0 DKA400 RRD43 3213 dva0.0.0.0.1 DVA0
5	From the SRM console, boot the OpenVMS CD-ROM. >>>boot -flags 0,0 dka400	Installation information is displayed and you are prompted to select an option. For more information, refer to the <i>OpenVMS Installation Guide</i> .

Equipment Log

Introduction

With the Equipment Log, you can gather information that you may need if problems occur with your system and you need to call Digital for assistance.

Use the Equipment Log to record information about your system hardware and software components. Update the Equipment Log when you add options.

Equipment Log

The log consists of six tables, which you can use to record the following information:

- Your system's hardware components (Table G-1).
- Your system's ISA equipment configuration (Table G-2).
- Your SCSI device address settings (Table G-3).
- Your system's system hardware configuration (Table G-4).
- The operating system or application software installed on your Digital AlphaServer 400 Series system (Table G-5).
- Additional components (Table G-6).

Equipment Log

Table G-1. Hardware Components

Component	Vendor/ Type/Size	Model Number	Serial Number	Date Installed
System unit	Digital AlphaServer	400 Series		
System unit key number				
Monitor				
Keyboard				
Mouse				
Installed diskette drive				
Additional storage device 1				
Additional storage device 2				
Additional storage device 3				
Additional storage device 4				

Use Table G-2 to keep track of your AlphaServer 400 Series system's expansion options. The upper portion of the table shows the standard devices. You can use the lower portion of the table to record the parameters of ISA devices you add to the motherboard expansion slots. The columns refer to information needed by the SRM console configuration database that is used on DEC OSF/1 AXP and OpenVMS AXP systems. See the ISACFG section of Appendix A for details on entering device parameters in the database.

Table G-2. ISA Equipment Configuration

Device	Handle	Slot	IOBASE	Membase and Memlen	DMA mode and chan	IRQ 0-3
Keyboard	KBD	0	60			1
Mouse	MOUSE	0	60			12
Serial Line 1	COM1	0	3F8			4
Serial Line 2	COM2	0	2F8			3
Parallel port	LPT1	0	3BC			7
FDC	FLOPPY	0	3F0		2	6
Motherboard ISA Expansion Slots						

Table G-3. SCSI Addresses

Address	Device
0	
1	
2	
3	
4	
5	
6	
7	SCSI controller

Equipment Log

Table G-4. Hardware Configuration

Component	Digital AlphaServer 400 Series System Specifics
CPU speed and model	
Firmware version	
Memory size	
Video module	

Table G-5. Installed Software

Operating System or Application Software	Version Number	License Number	Date Installed

Table G-6. Additional Components

Component	Vendor	Model Number	Serial Number	Date Installed

Index

A

- Abbreviations used, xv
- Add-on procedure
 - expansion boards, 3-8
 - ISA options on DEC OSF/1 or OpenVMS, 3-9
 - lower bay devices, 3-17
 - mass storage, 3-10
 - memory, 3-7
 - SIMMs, 3-7
 - upper bay devices, 3-12
- Adding memory, 3-6
- ARC console, A-1
 - autobooting, A-3
 - boot command, A-3
 - boot menu, A-1
 - boot selection menu, A-2
 - booting an alternate operating system, A-3
 - install new firmware, A-3
 - install Windows NT, A-4
 - main menu, A-1
 - switching to OSF or OpenVMS console, A-4
 - switching to the SRM console, A-4
- Audience, xiii

B

- Baud rates
 - serial port, C-4

C

- Cable orientation, 3-14
- Cleaning
 - computer, B-1
 - monitor screen, B-1
- Components
 - motherboard, 3-4
- Computer
 - cleaning, B-1
 - controls and indicators, 2-4
 - equipment log, G-1
 - initial troubleshooting, 4-1
 - moving, B-3
 - packing, B-3
 - security, 1-15
 - side panels, 3-1
 - specifications, C-1
 - system box
 - troubleshooting, 4-2
 - system unit components, 3-3
 - turning off, 1-14
- Connector
 - bidirectional, C-3
 - parallel, C-3

Index

Console

- switching from ARC to SRM, 1-13
- switching from SRM to ARC, 1-13

Console commands, A-1

Console update utility, E-1

Controls and indicators, 2-5

Conventions used, xiv

Cooling, 1-8

D

DEC OSF/1, 1-12

- shutdown, 1-14

Device mapping, D-1

DMA channel assignments, D-3

E

Environment variables, A-7, A-16

- auto_action, 1-11, A-16

- boot_file, A-16

- boot_osflags, A-16

- bootdef_dev, A-16

- console, A-16

- control_scsi_term, 3-11, A-16

- modifying, A-9

- os_type, A-16

- pci_parity, A-16

- setting, A-9

Equipment log, 4-2, G-1

- hardware components, G-2

- hardware configuration, G-4

- installed software, G-4

- SCSI addresses, G-3

Ergonomics, 1-2

ESD precautions, C-7

Expansion board, 3-8

- installation, 3-8

Expansion slot

- current limitations, C-1, C-6

- power, C-6

F

Features

- keyboard, 2-2

- PCI, 2-2

- SCSI, 2-2

Firmware

- update utility, E-1

- updating, E-1

Flash update utility, E-2

Floppy eject button, 2-5

Formatting

- arcinst, F-4

H

Halt button, 2-5, 4-1

I

I/O addresses, D-1

Indicators and controls, 2-5

Initial troubleshooting, 4-1

input power requirements, C-6

Install

- lower bay device, 3-17

- mass storage devices, 3-10

- option module, 3-8

- upper bay device, 3-12

IRQs, D-2

ISA configuration (ISACFG) utility, A-17

ISACFG utility, 3-9, A-17

J

Jumper

- changing settings

- precautions, C-6, C-7

Jumpers

- motherboard, C-6

K

Keyboard, 2-2
 angle, 2-2
 cleaning, B-2
 connector, C-4
 key groups and functions, 2-3

L

LEDs
 diagnostic, 4-1, 4-7
 values, 4-8
 Lifting components, 1-2
 Lower bay
 assembly, 3-18, 3-19
 device, 3-17

M

Mass storage devices, 3-10
 Memory
 banks, 3-6
 configurations, 3-6
 installing, 3-6
 Monitor adjustments, 1-11
 Motherboard
 components, 3-4
 jumpers, C-6
 Mouse connector, C-4
 Moving your computer, B-3

N

Network connection, 1-11

O

OpenVMS, 1-12, 1-13
 shutdown, 1-14
 Option installation, 3-8
 Option module, 3-8
 OSF/1, 1-12

shutdown, 1-14

P

Packing
 computer, B-3
 Padlock ring, 1-15
 Parallel port connector, 2-7
 Passwords, 1-15
 PCI, 2-1
 Pinouts
 bidirectional parallel port, C-3
 parallel, C-3
 SCSI port, C-5
 serial connectors, C-4
 Posture, 1-2
 Power
 auxiliary jack
 current limit, 1-10
 cabling, 3-16
 switch, 1-9, 1-11, 2-5
 Precautions
 changing jumper settings, C-6, C-7
 ESD, C-7
 system cleaning, B-1
 Preloaded software, 1-12
 Problem solving, 4-1

R

Rear panel, 2-6
 connector functions, 2-6
 view, 2-7
 Removing side panels, 3-1, 3-2
 Reset button, 2-5, 4-1

S

SCSI
 addresses, 3-11
 bus length, 3-10
 cable orientation, 3-14

Index

- controller, 2-2
- port, C-5
- termination, 3-11
 - external, 3-11
 - internal, 3-11
 - software controlled, 3-11
- Security, 1-15
- Serial port, C-4
 - baud rates, C-4
- Shutdown, 1-14
- Side panels, 3-1
 - removing, 3-1, 3-2
 - unlocking, 3-1, 3-2
- SIMMs, 3-6, 3-7
- Site preparation
 - cooling, 1-8
 - ergonomics, 1-2
- Software license
 - notice label, 1-2
- Specifications
 - acoustic, C-2
 - computer, C-1
 - computer dimensions, C-2
 - computer performance, C-1
 - environmental, C-2
- SRM console, A-5
 - boot command, A-7
 - boot command examples, A-8
 - conventions, A-5
 - deposit command, A-14
 - deposit command examples, A-15
 - environment variables, A-16
 - examine command, A-12
 - examine command examples, A-13
 - ISACFG command, A-17
 - set command, A-9
 - set command examples, A-9
 - show command, A-10
 - show command examples, A-11

- special characters, A-6
- Startup
 - connecting components, 1-9
 - power on sequence, 1-11
 - voltage selection, 1-9
- System
 - box
 - troubleshooting, 4-2
 - controls and indicators, 2-4
 - front view, 2-4
 - interrupt assignments, D-2
 - physical security, 1-15
 - rear view, 2-7
 - starting, 1-11
 - troubleshooting, 4-1

T

- Termination
 - SCSI, 3-11
- Troubleshooting
 - boot device not listed, 4-4
 - boot problem, 4-3
 - computer, 4-2
 - disk read and write problem, 4-6
 - display problems, 4-6
 - initial, 4-1
 - keyboard, 4-5
 - monitor power indicator problem, 4-6
 - mouse, 4-5
- Turning off system, 1-14

U

- Unlocking side panels, 3-1, 3-2
- Update utility, E-1
- Upper bay device, 3-12

V

- Ventilation, 1-8
- Voltage selector switch, 1-9, 2-7

W

Windows NT, 1-12

arcinst, F-3

creating partitions, F-3

partitioning the disk, F-3

shutdown, 1-14

starting an install, F-2

4